

# Omega User Programs Update and Perspective on FY23 OLUG Findings and Recommendations Status

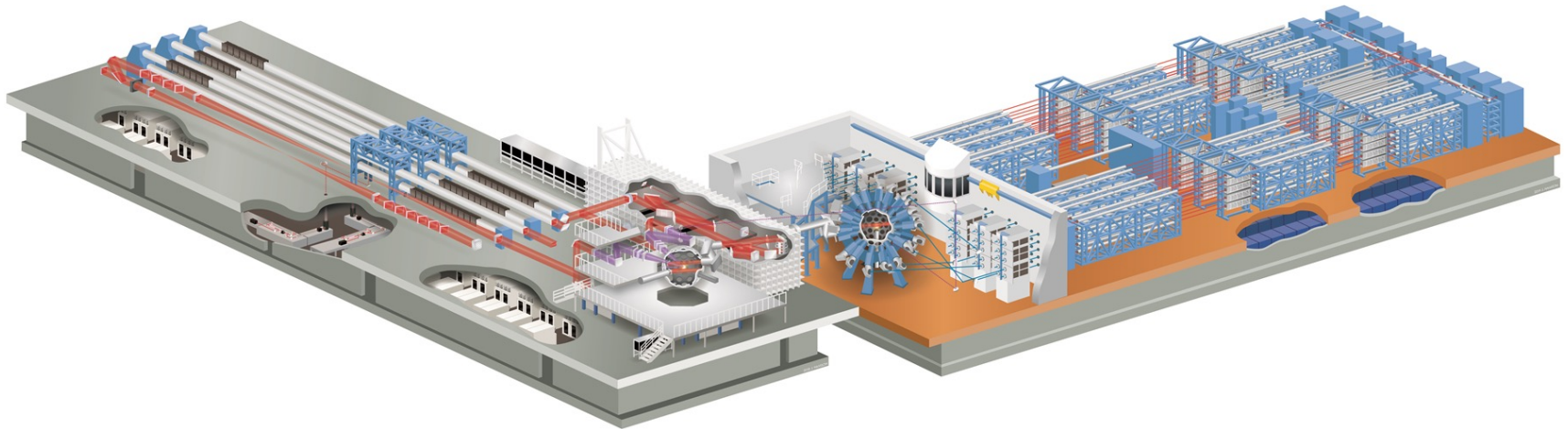

**Mingsheng Wei, Sam Morse**  
**University of Rochester**  
**Laboratory for Laser Energetics**

**OLUG @ APS-DPP**  
**Denver, Co**  
**30 October 2023**

# OLUG APS-DPP update – LLE values the Users' F&Rs and strives to address them



- **Omega Facility delivered 2061 shots in FY23**
- **Progress continues on prior year OLUG Findings and Recommendations (F&Rs)**
- **LLE has started sustainment activities to extend Omega into the 2030's**
- **Plans are in place to address many of the 2023 F&Rs**

# Omega Facility delivered 2061 shots in FY23 ~28% for the Basic Science User Programs

- **Basic Science open-access users (NLUF, LBS and LaserNetUS) obtained a total of 568 target shots in FY23**
  - 50 unique projects
  - 70+ graduate students
  - NNSA provided additional \$0.5M funds for NLUF targets
- **Shots scheduled in FY24**
  - 26 NLUF
  - 15 LBS
  - 2 LaserNetUS

## FY23 Omega Laser Facility Shots

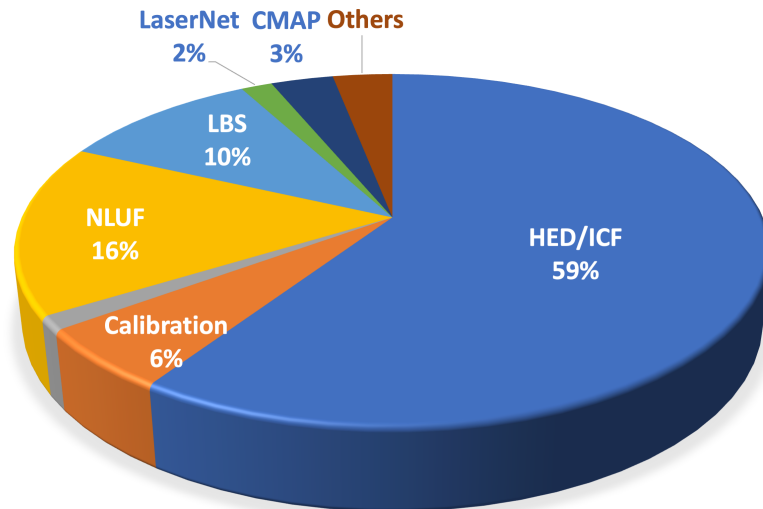

External users conducted 55% of the shots

# The Diagnostic Development and Integration Group

## Supports many diagnostic projects



### Major diagnostics qualified on Omega in FY23

- Omega continues to be a hub of diagnostic innovation
- The DD&I group leads integration projects (S. Ivancic, [siva@lle.Rochester.edu](mailto:siva@lle.Rochester.edu))
- LLE is committed to a number of new and/or modified diagnostics for FY24 shots

Diagnostic Name	Lead Lab	Diagnostic description
Omega High Resolution Velocimeter (OHRV)	LLE/LLNL	LLNL supplied a new laser front end integrated into the OMEGA laser bay. LLNL and LLE are working to transfer operations, specialist, and data analysis responsibilities onto LLE staff.
Multi frame Zone plate Imager	LLE	A system consisting of an hCMOS sensor on OMEGA coupled to a Fresnel zone plate imaging system. LLE is collaborating with SNL on fielding the hCMOS on the Fresnel Zone Plate imager.
Polarization Resolved Ultraviolet Thomson Scattering	LLNL	This design uses a Wollaston prism to simultaneously separate signal polarizations and disperse the UV light.
Full Aperture Backscatter P9	LLE	Refurbishment project of the OMEGA backscatter station. New spectrometers were procured in FY23 and two ROSS streak camera systems were upgraded with optical calibration modules to integrate with the new spectrometers.
Electron Spectral Imager	LLE	Designed to collect wide-angle (~120 degrees) electron spectrum from short-pulse experiments.
Spectroscopy Resolved Streaked Optical Pyrometer	LLE	SOP-Spec is capable of measuring temperature down to 3000K, and wavelength dependent emissivity and reflectivity of compressed materials in the ~400-850 nm range with ~100 ps temporal resolution.

# LLE has started half of the 54 OMEGA Sustainment activities



- The plan boosts sustainment over the period of current Cooperative Agreement (CA), FY24-28
- Omega Sustainment consists of 54 discrete activities assigned to OMEGA-60, OMEGA EP, and cross-cutting Enabling Technology areas

# SOP-Spec is capable of measuring broad-band emission spectra in the 450-750 nm wavelength range

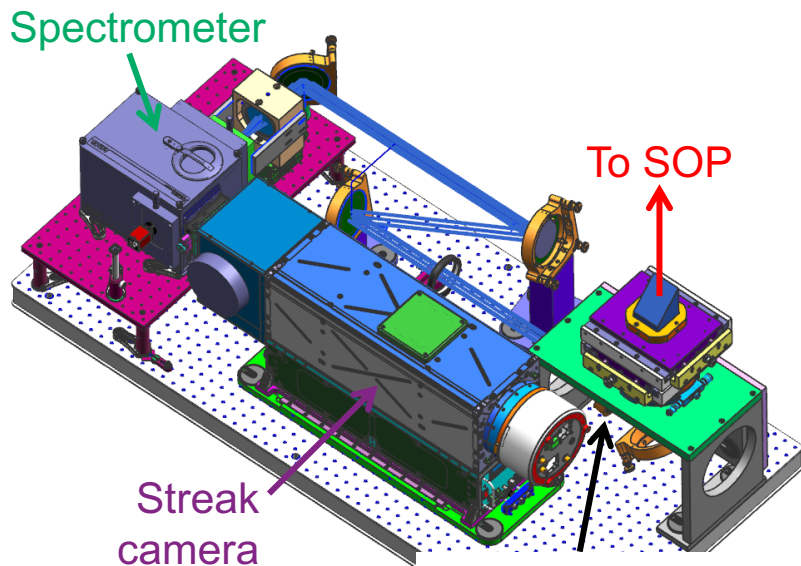

Data from first use (not sensitivity corrected)

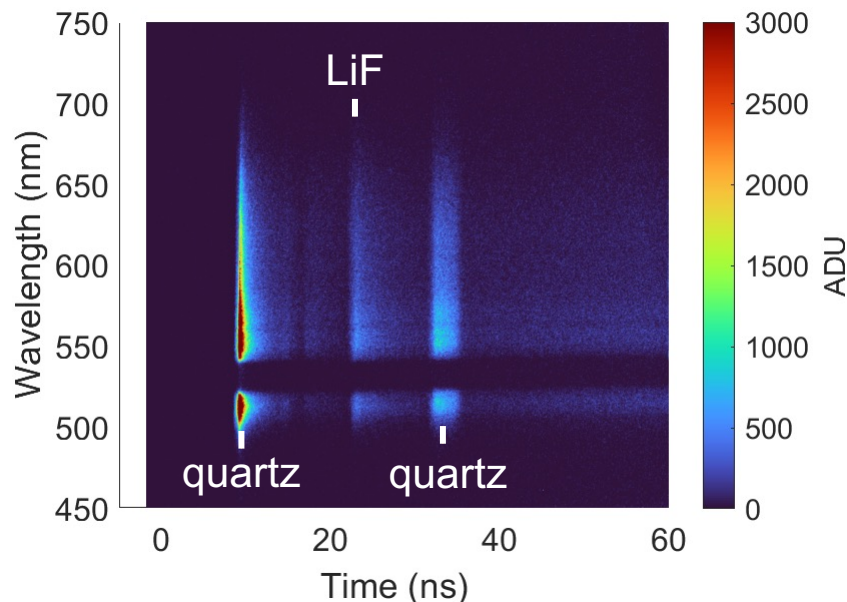

SOP-Spec can be run along with SOP using a 50:50 beam splitter. It will be ready for general use after 11/22/2023. Contact: [neelkabadi@lle.rochester.edu](mailto:neelkabadi@lle.rochester.edu)

# EP VISAR and SOP to TIM-14 (an OLUG request) will be available in Q2FY24

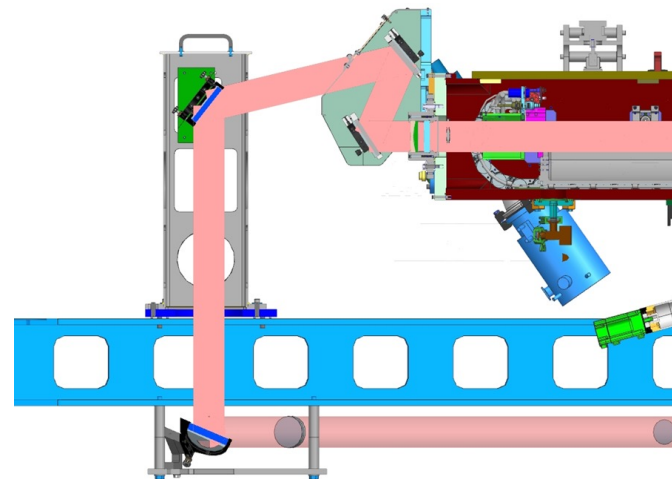
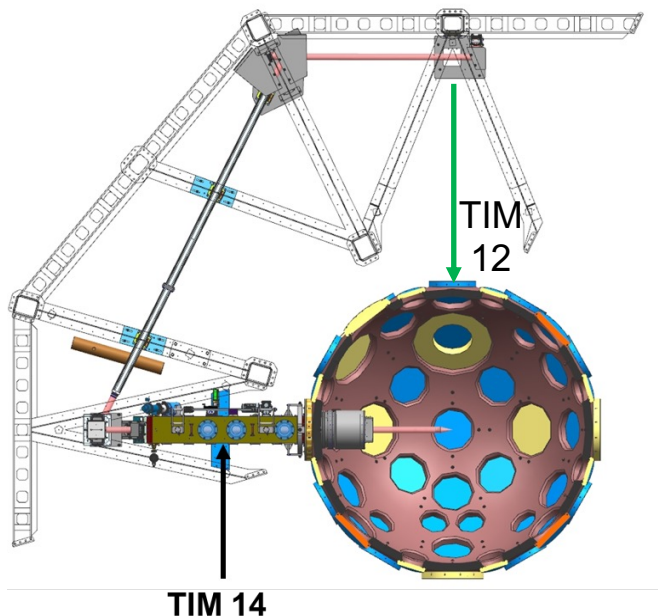

Side-on View of TIM 14

This project utilizes the existing telescope from TIM 12. ASBO will only be able to run in TIM 12 or TIM 14 and not simultaneously in both.

# New Active Shock Break Out (ASBO) Lasers

- Two lasers are in fabrication to replace the two obsolete units in OMEGA and OMEGA EP
- The lasers are scheduled for delivery and commissioning in May 2024

System front-end oscillator

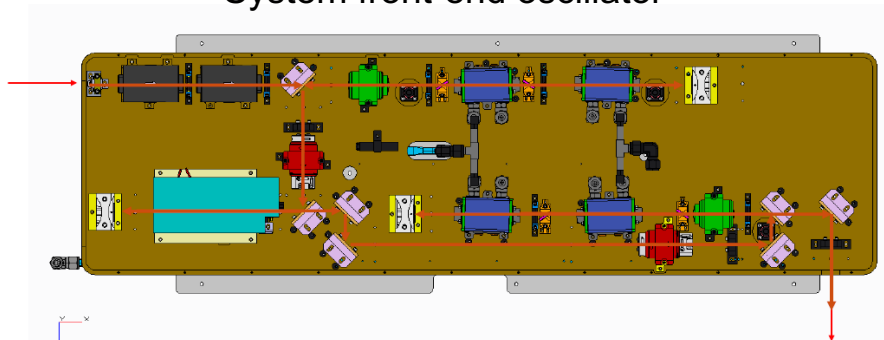

System amplification and second harmonic conversion

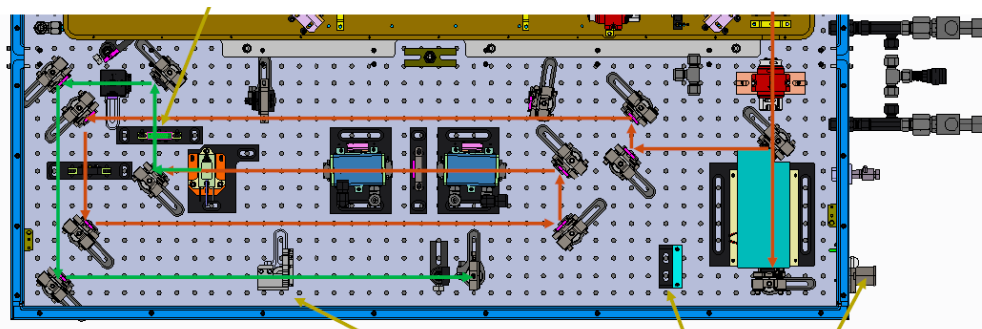



# DANTE refurbishment (partner with LLNL) will continue into FY25

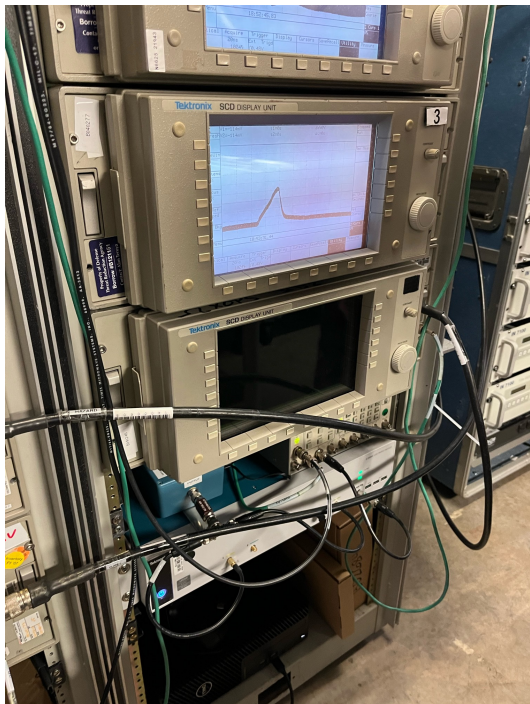

- **Four new four-channel digital oscilloscopes (thank you, LLNL!)**
- **The new system includes a timing fiducial channel**

# Plans are in place to address many of the 2023 OLUG F&Rs



1. **Display requested beams from min to max in SRF Omega 60**
2. **Film digitization: improve 3-month lead time**
  - Providing access and training PIs in the operation of the PDS scan system
3. **3rd driver on Omega-60**
  - Would be a major undertaking with protracted downtime
4. **Increase possible time delay between UV drive beams on OMEGA EP to >650 ns**
  - would be a large-scale project
4. **Interstrip timing for framing cameras on shot images and reports**
  - Added timing checker; users' guide will be updated.
6. **Fiducial timing and dispersion information for time-resolved Thomson scattering on shot images and reports**
7. **Add additional TPIE**
  - Cost estimated and will be submitted for prioritization in FY24 projects

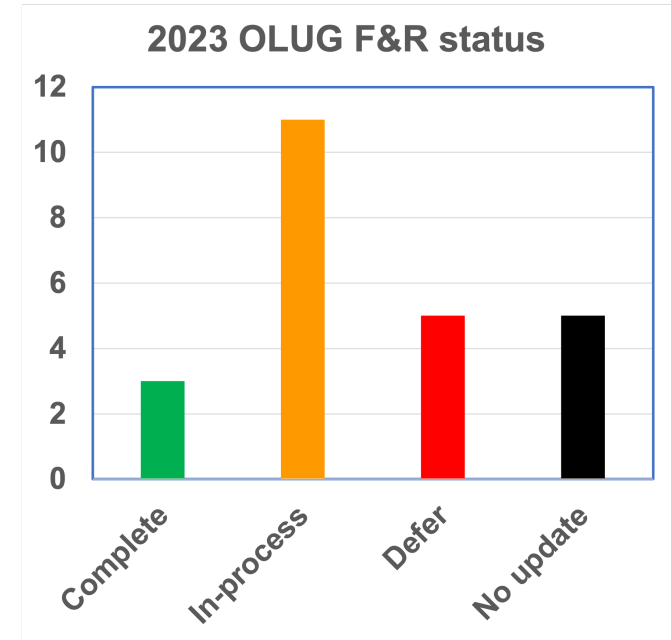

# Plans are in place to address many of the 2023 OLUG F&Rs



## 8. Front light the TVS views

- Sustaining the current system has the priority

## 9. Improved target alignment capabilities for targets away from TCC

- PIs should consult with LLE target fab adding alignment features for critical alignment

## 10. Add beam timing at long timing delays on EP (report on-shot beam timing when pulses are not captured on UV ROSS)

- An on-shot timing report that includes both UV ROSS and PSM values is being created and will be available on the EP Shot Images and Reports web page later this year.

## 11. Planar Cryo on EP

- A major effort; deferred in FY24 and to be reconsidered in FY25.

## 12. Access to Omega-60 through LaserNetUS (to support IFE research) (alternatively, NLUF time could consider IFE work in its facility time solicitation)

- No (beyond the current facility capacity), and Yes (if proposals meeting NLUF objectives and recommended by review committee)

## 13. Long LoS diagnostic port(s) on EP

## 14. Add collimators to EP NTOFs

# Plans are in place to address many of the 2023 OLUG F&Rs



15. **Integration of pulsed power capabilities with Omega/Omega-EP & FLUX operations\*** (simply requesting that the concept begins being socialized)
16. **Gate valve for NTD nosecone swapping**
  - A potentially viable solution determined; will be submitted for prioritization in FY24 projects
17. **OMEGA MediaWiki and/or Q&A forum to crowdsource guides and reference materials**
18. **Increase user information accessibility**
19. **PI training week - more in-depth information for running shots**
20. **Capability to infer directional flow vector on D2-gas-filled or low DT yield implosions**
  - Options identified but would require a significant effort. Justification from OLUG is crucial to proceed.
21. **Better colormap bounds on Shot Images and Reports**
  - Smart scaling for display is being added; PIs are advised to utilize the ‘Diagnostic Analysis Tools’ link directly under shot-images and reports.

# Plans are in place to address many of the 2023 OLUG F&Rs



22. **Implement the MIFEDS Gen-3 for generation of very high initial B-fields**
  - Gen-3 system being tested in the MIFEDS lab; need to address debris issue.
23. **Targets: Improve process, from request to shot day, for better overall outcomes**
  - NLUF target funding remains very challenging
24. **IR DPP for OMEGA EP (better Omega EP short pulse reproducibility for improved x-ray backlight source)**

# LLE values the Users' F&Rs and strives to address them



- **Omega Facility delivered 2061 shots in FY23**
  - 28% for the Basic Science User Programs
- **Progress continues on prior years' OLUG Findings and Recommendations (F&Rs)**
- **LLE has started sustainment activities to extend Omega into the 2030's**
- **Plans are in place to address many of the 2023 F&Rs**

**LLE plans to issue call for proposals for FY25 LBS program. LLE will continue to participate in the LaserNetUS calls (Cycle 6 proposals are due by Dec 12, 2023).**

**15<sup>th</sup> OLUG Workshop  
at UR/LLE  
April 16–18, 2024**



# NSF awarded a midscale research infrastructure (RI-1) project to design EP-OPAL, a user facility to address scientific questions in four research areas



## High-Field Physics and Quantum Electrodynamics (HFP/QED)

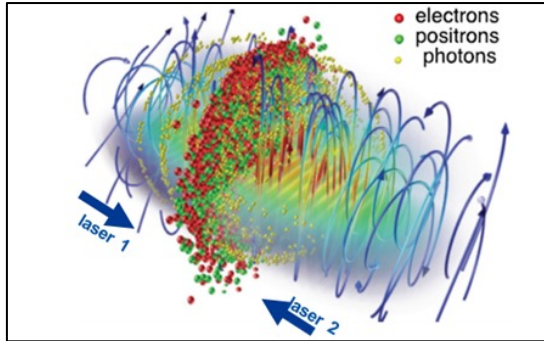

## Particle Acceleration and Advanced Light Sources (PAALS)

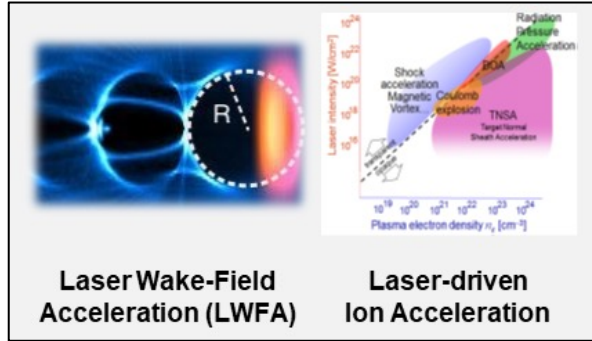

Laser Wake-Field Acceleration (LWFA)

Laser-driven Ion Acceleration

## Laser-Driven Nuclear Physics (LDNP)

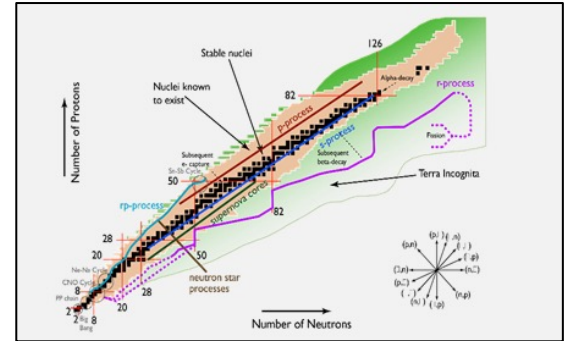

## Laboratory Astrophysics and Planetary Physics (LAPP)

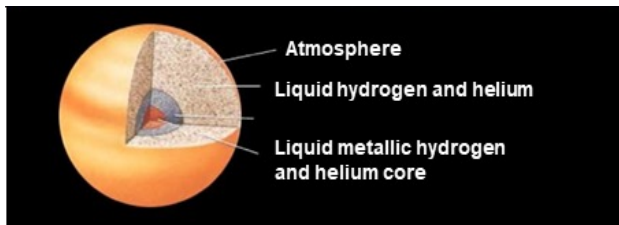

Join one (or more) of the EP-OPAL Frontier Science Working Groups to participate in defining the needs for future experiments by using this QR code and/or going to <https://www.lle.rochester.edu/ep-opal/>

