



# High Energy Density Physics Research at Sandia National Laboratories

Ramon J. Leeper  
representing the Pulsed Power Sciences Center  
Sandia National Laboratories  
Albuquerque, New Mexico

April 27, 2012



# **Sandia National Laboratories is one of three Department of Energy's NNSA laboratories**

- **Sandia National Laboratories is a government owned/contractor operated (GOCO) facility operated by Lockheed Martin Corporation as a set of multi-program laboratories for the U.S. National Nuclear Security Administration (NNSA)**
- **Sandia currently has 8980 employees and a operating budget of approximately \$2.5 billion**
- **Major locations include Albuquerque, New Mexico (~ 8055 employees) and Livermore, California (~925 employees)**
- **Sandia's precursor was Los Alamos National Laboratory's Z Division created in 1945 as part of the Manhattan Project**
- **Sandia separated from Los Alamos in 1949 and ATT took over its initial operation at the direct request of President Truman**



# **Sandia broadly contributes to the national HEDP and ICF programs in a number of important areas**

- Sandia leads the national effort in pulsed power HEDP and ICF research**
- Sandia operates the Z and Z-Beamlet facilities for the national program**
- Since 1995, the Sandia program has participated and contributed to the NIF diagnostic effort in the areas of x-ray and nuclear diagnostics**
- Sandia is now actively engaged in the NIC physics efforts in the areas of ablator physics, shock timing, and neutron measurements**
- For over a decade we have had an active collaboration with MIT in the development and calibration of nuclear diagnostics**
- The Sandia program is now actively developing a fundamental science user program on the Z and Z-Beamlet facilities that has resulted in active collaborations with the CEA, Cornell University, Imperial College, LANL, LLNL, Swarthmore College, University of Michigan, University of Nevada-Reno, University of New Mexico, University of Texas-Austin, and the Weizmann Institute**
- The Sandia HEDP and ICF program employs approximately 155 technologists and technical staff plus another 80 contractors**

# MIT/SNL collaboration in action at the MIT Cockcroft-Walton

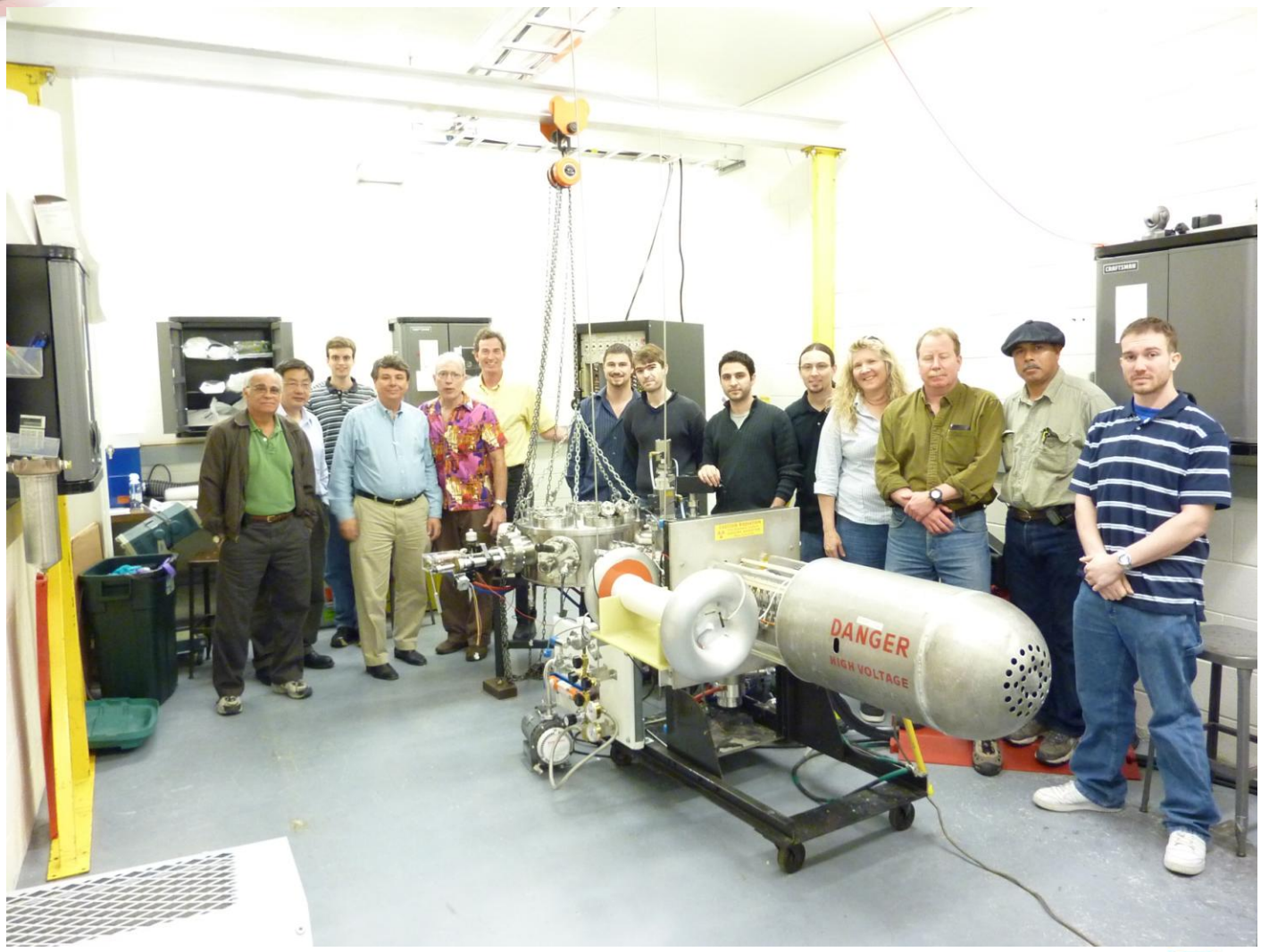



Regimes of high energy density are typically associated with energy density  $10^5 \text{ J/cm}^3 = 1 \text{ Mbar}$

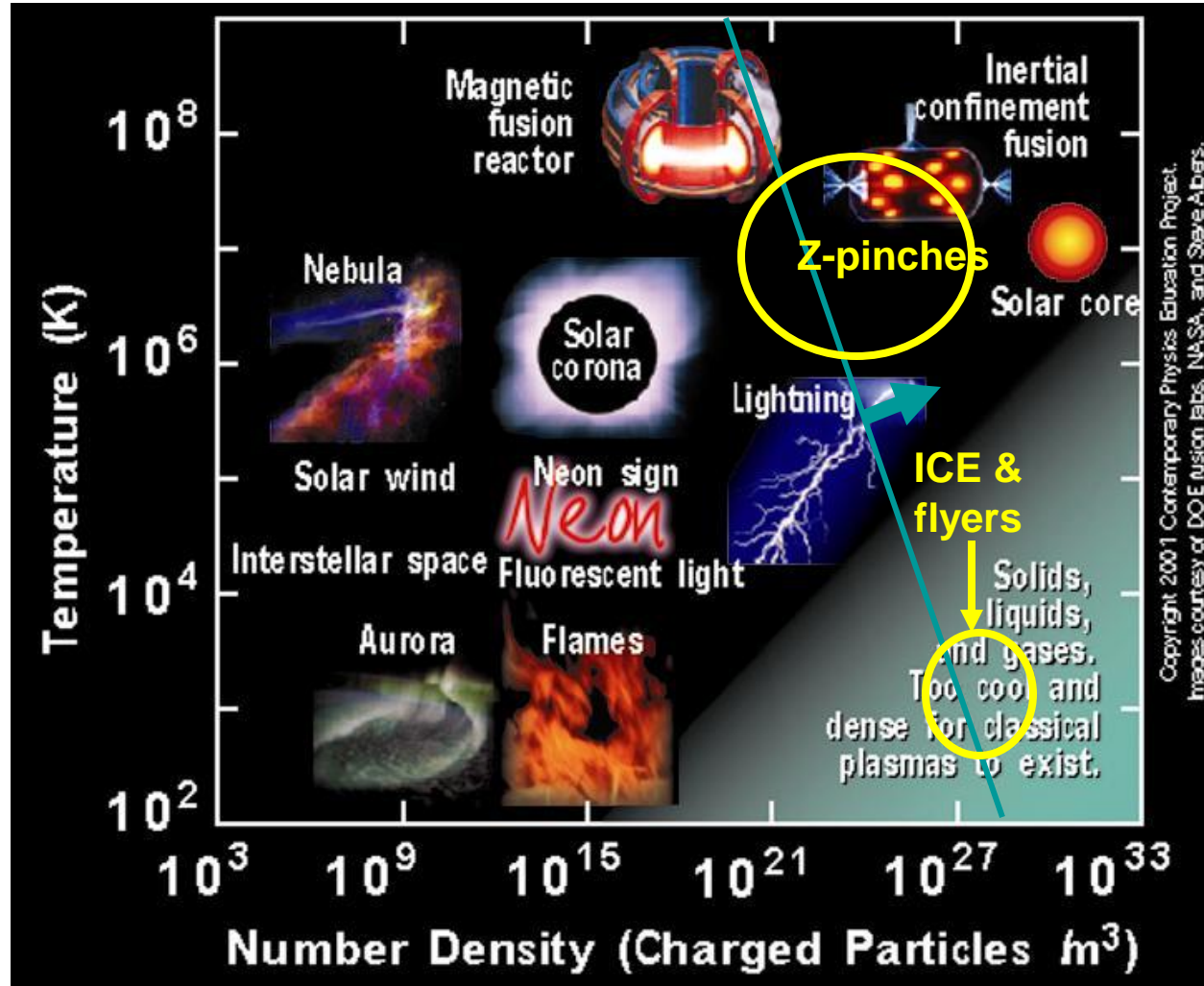

Copyright 2001 Contemporary Physics Education Project.  
Images courtesy of DOE fusion labs, NASA, and Steve Abrams.

Copyright 2001 Contemporary Physics Education Project



Z has a unique role as one of the three major US facilities for High Energy Density Physics (HEDP) experiments

Refurbished Z (2007)  
(3 MJ)

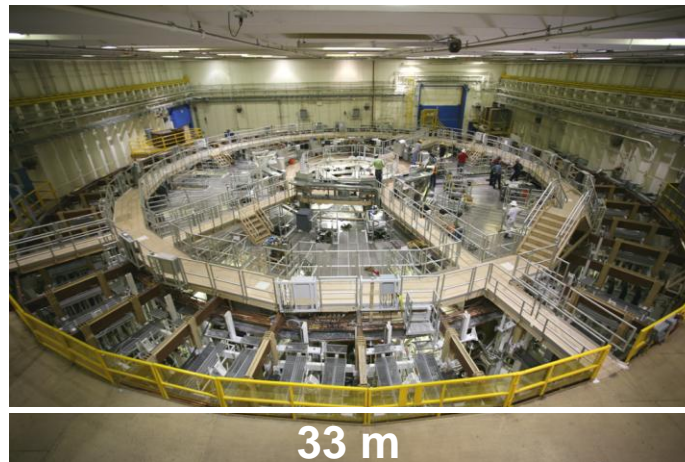

NIF (2009)  
(1.8 MJ @ 0.35  $\mu\text{m}$ )



OMEGA  
(30 kJ @  
0.35  $\mu\text{m}$ )

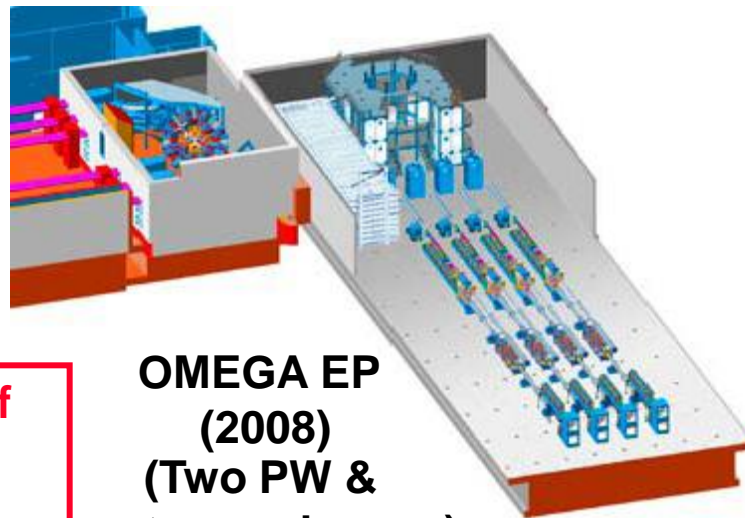

OMEGA EP  
(2008)  
(Two PW &  
two ns beams)

After 40 years of research, the components of simulations, drivers, diagnostics, and targets are in place to test ignition concepts



“Z” is the world’s largest pulsed power facility

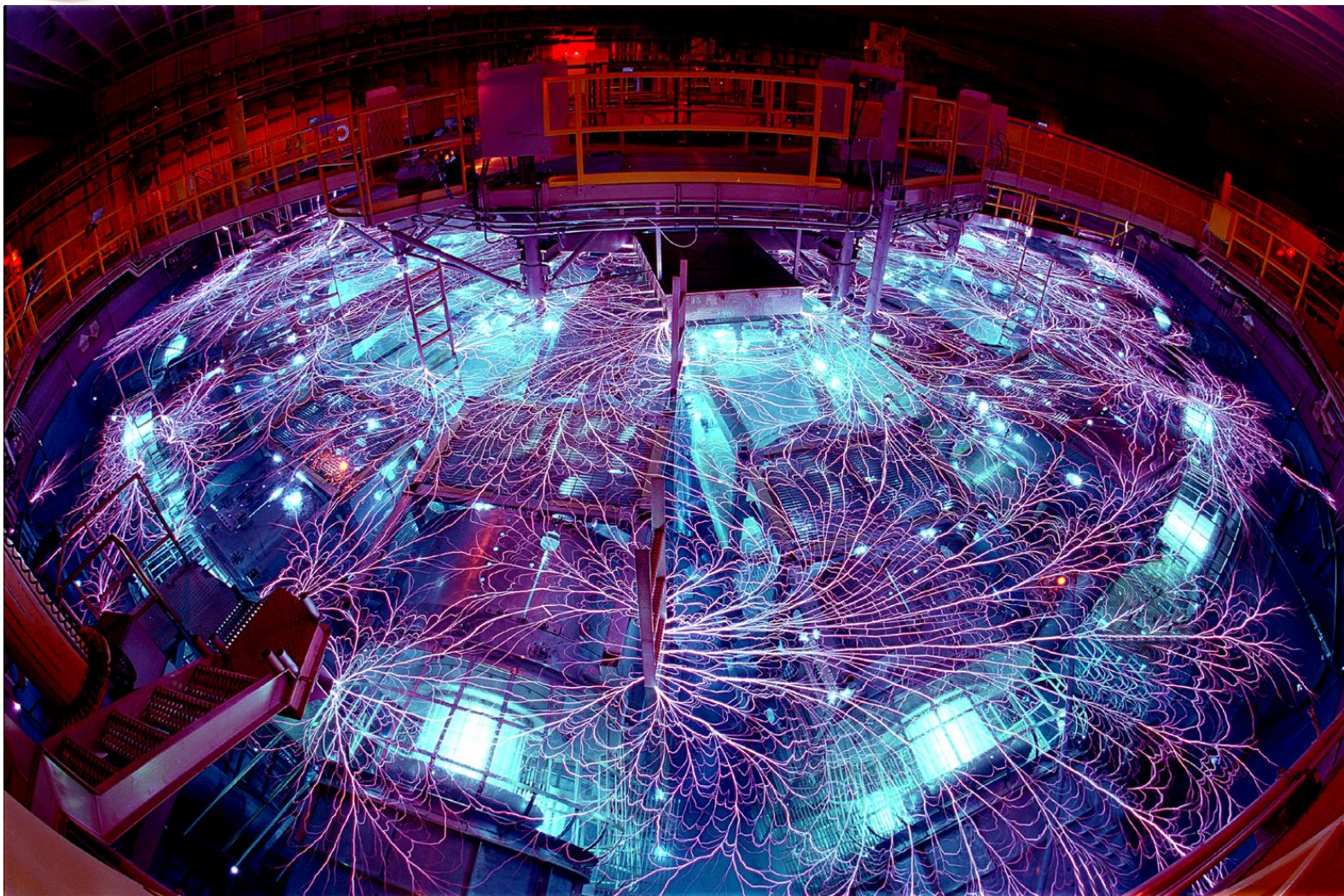



# The “Z” pulsed power facility is located at Sandia National Laboratories in Albuquerque, New Mexico

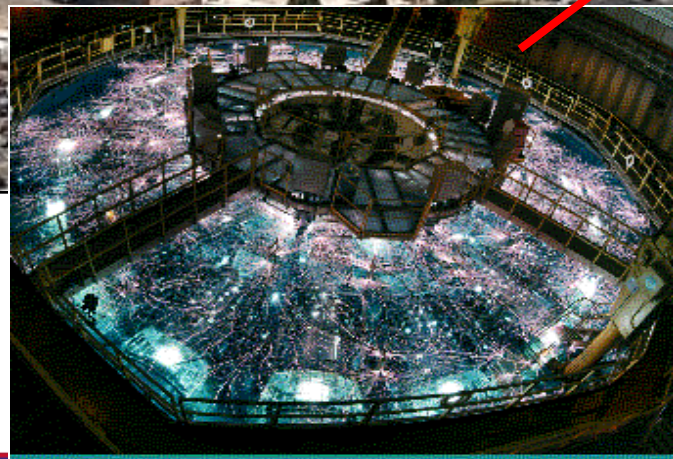





# Z compresses electrical energy to produce short bursts of high power.

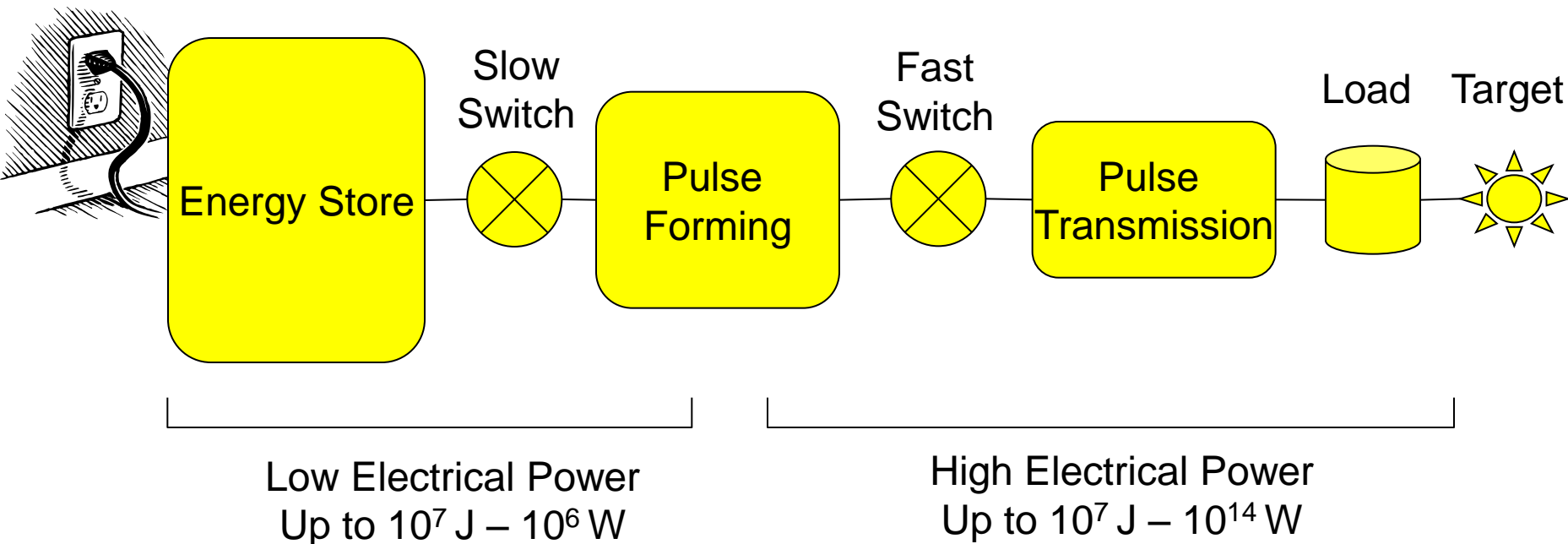

Goal: “Take the equivalent energy required to operate a TV for a few hours (1-2 MJ) and compress it into more electrical power than provided by all the power plants in the world combined (~15 TW)”

...S T Pai & Qi Zhang, “Introduction to High Power Pulse Technology,”  
World Scientific Publishing Co., Singapore, 1995.



# We use pulsed power drivers to create and study matter at high energy densities

High Current

Z-pinch x-ray source

Magnetic pressure

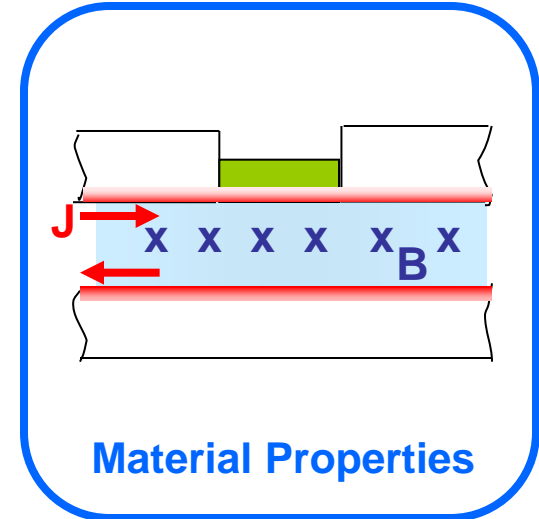
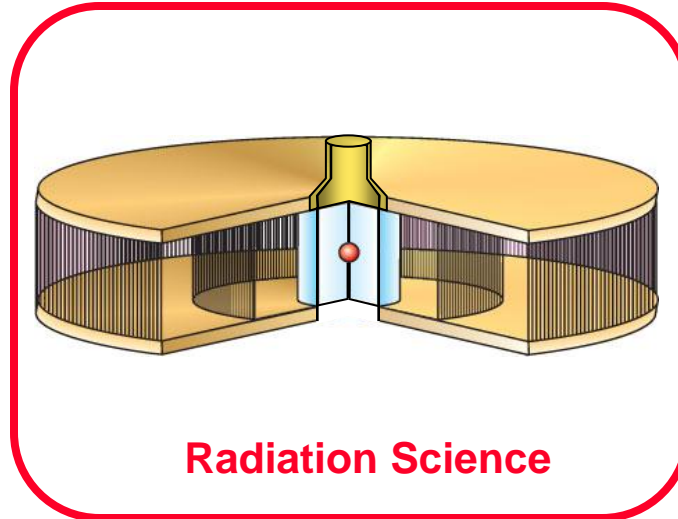
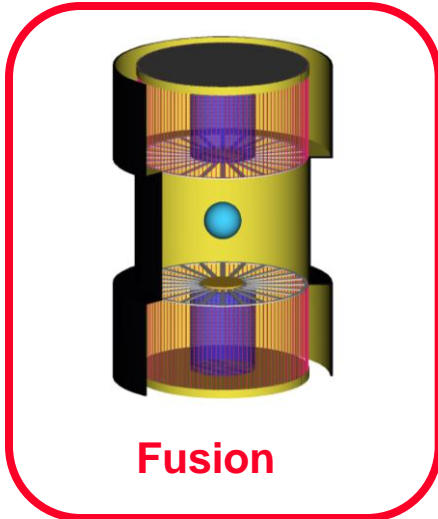
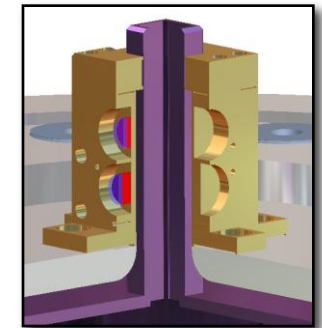
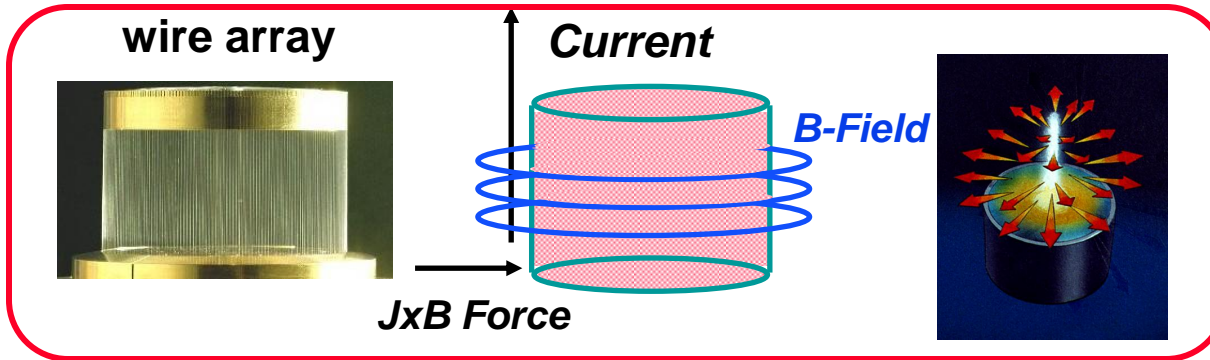



# A series of capacitors, transmission lines and switches achieves temporal and spatial compression on Z

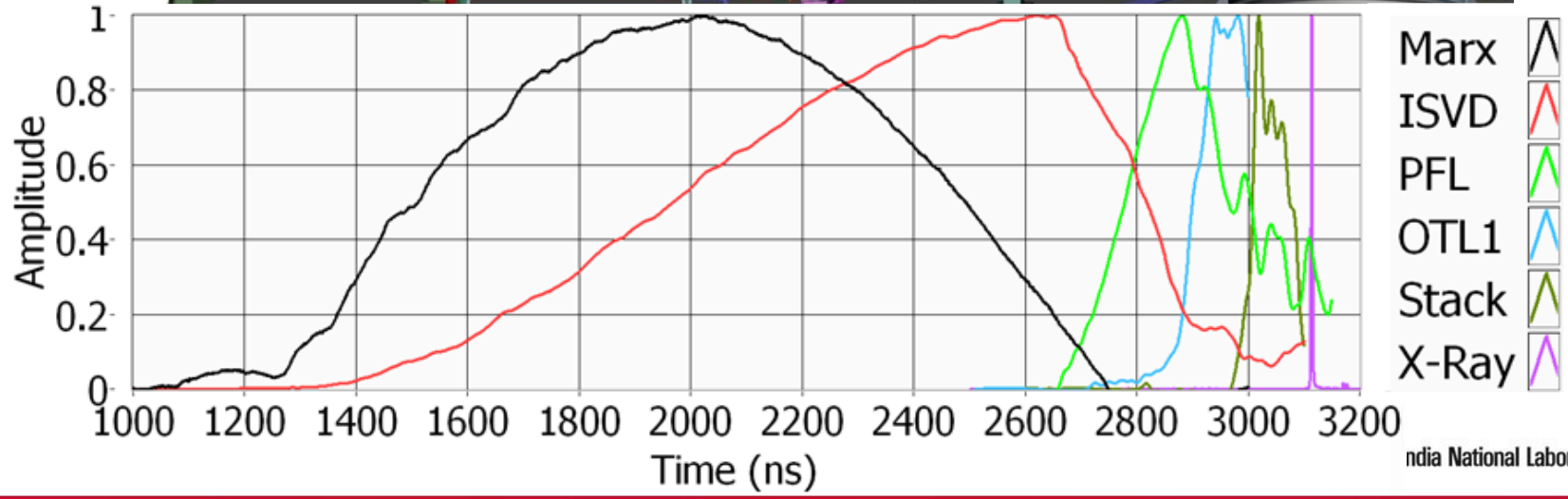
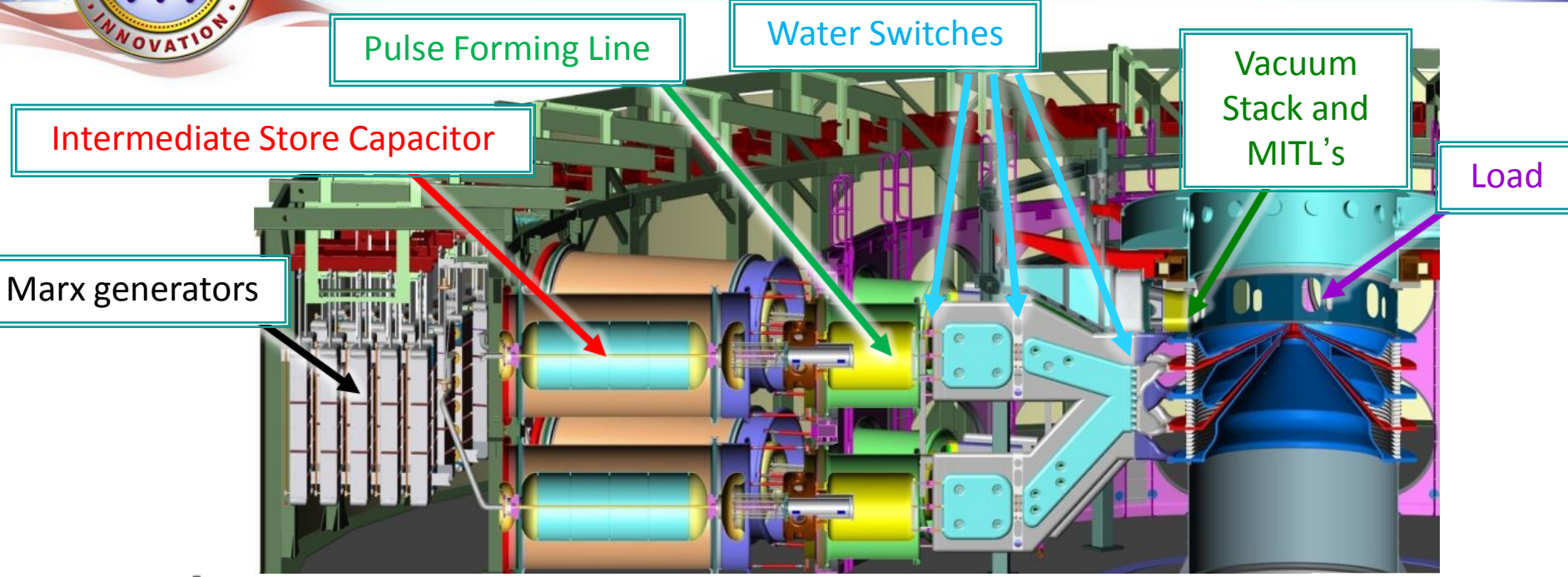



# The Refurbished Z Machine has more energy and more pulse shape flexibility

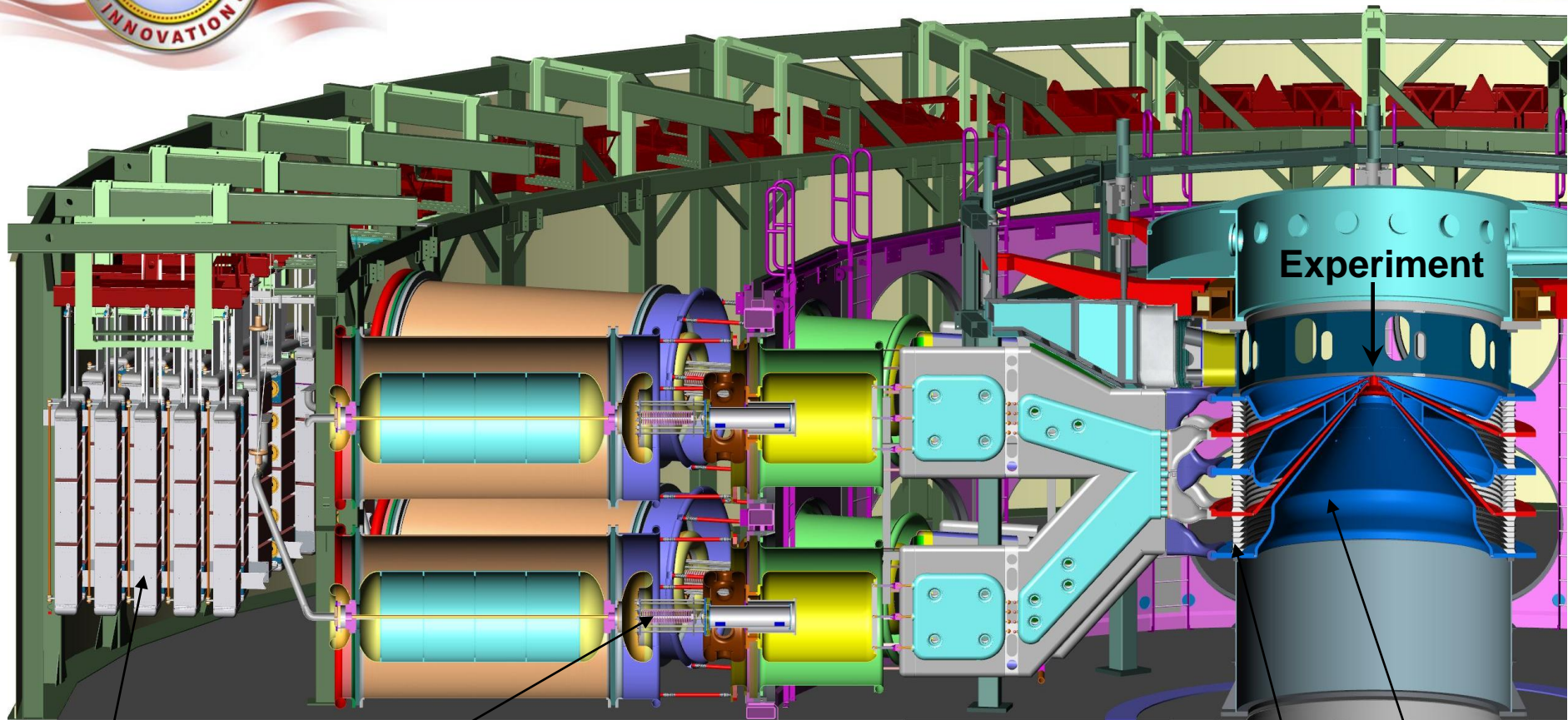

Marx generator

laser-triggered gas switch

**22 MJ stored energy (up from 11 MJ)**  
**~26 MA peak current (~18MA)**  
**~100-600 ns rise time**

insulator stack

magnetically insulated transmission lines



# Z Facility Overview

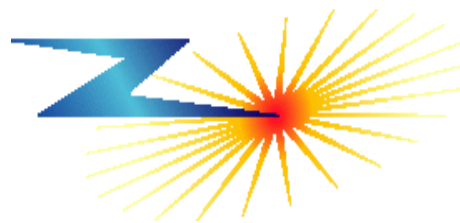
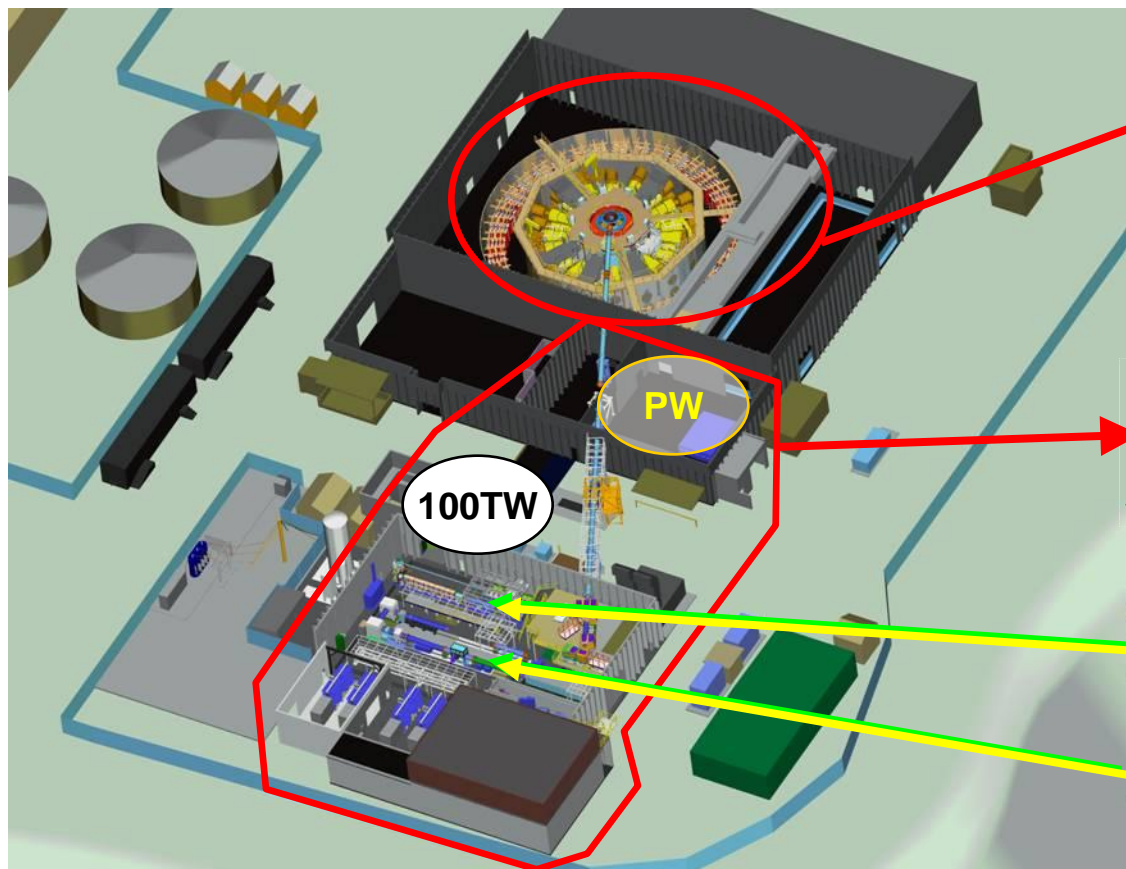



# The Z-Beamlet and Z-Petawatt laser backlighters provide a powerful new capability for diagnosing Z experiments

laser building

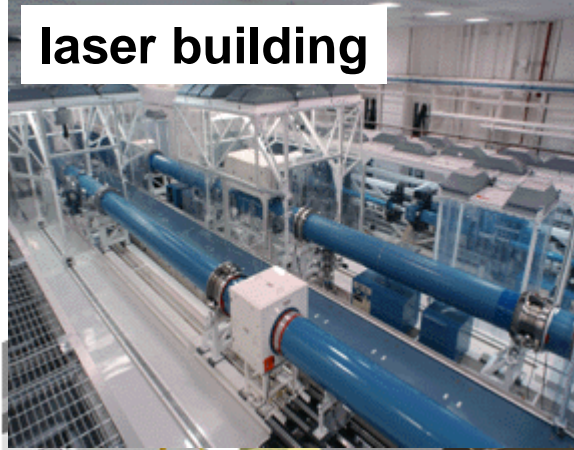

Z facility



imploding capsule

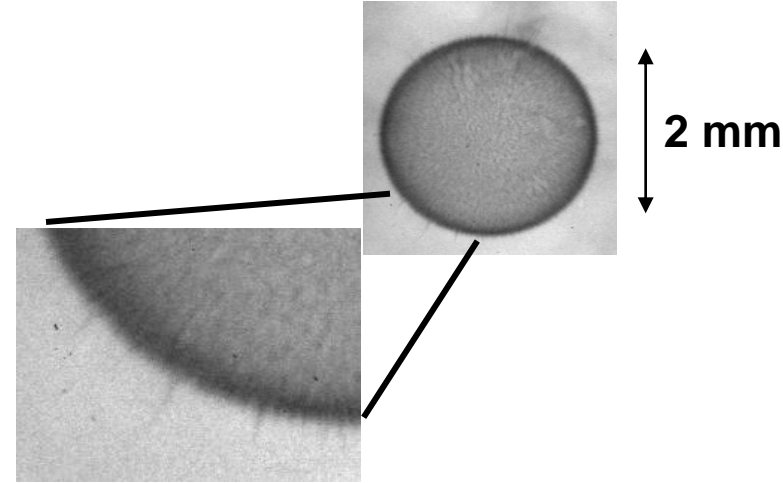

imploding z-pinch

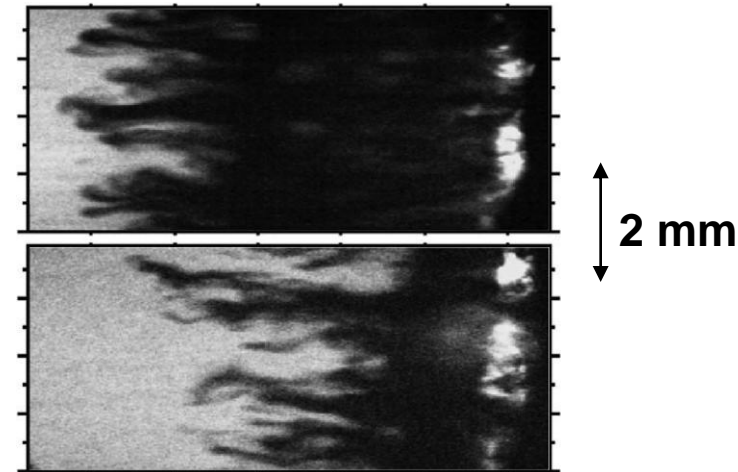

Z-Beamlet and Z-Petawatt lasers



# We use pulsed power drivers to create and study matter at high energy densities

High Current

Z-pinch x-ray source

Magnetic pressure

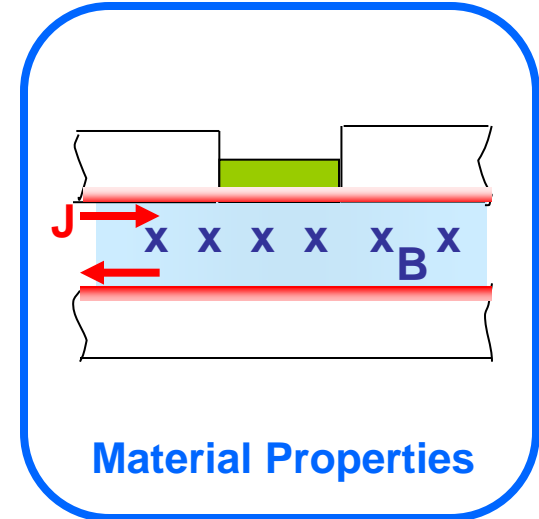
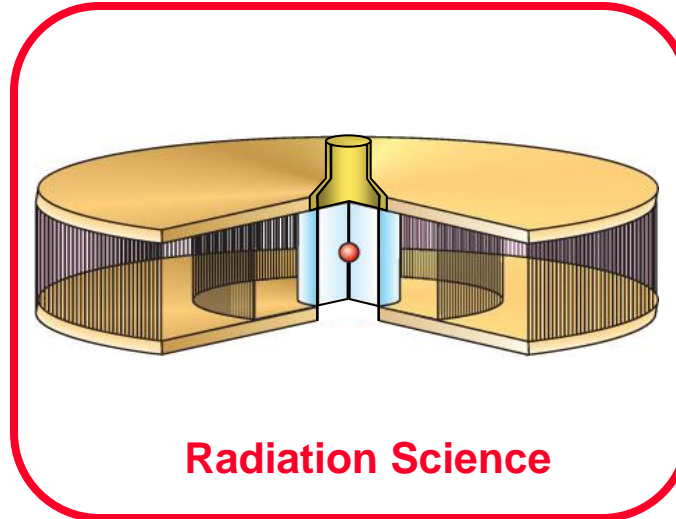
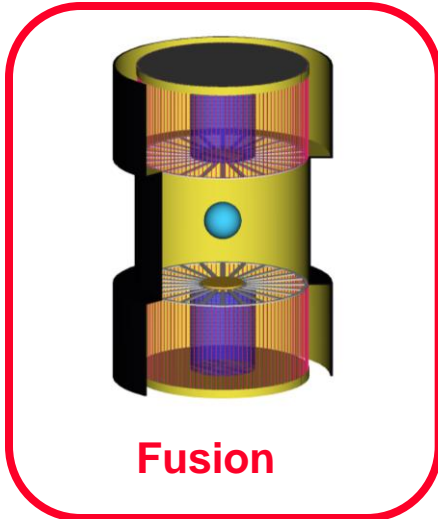
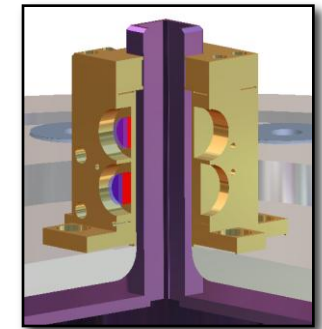
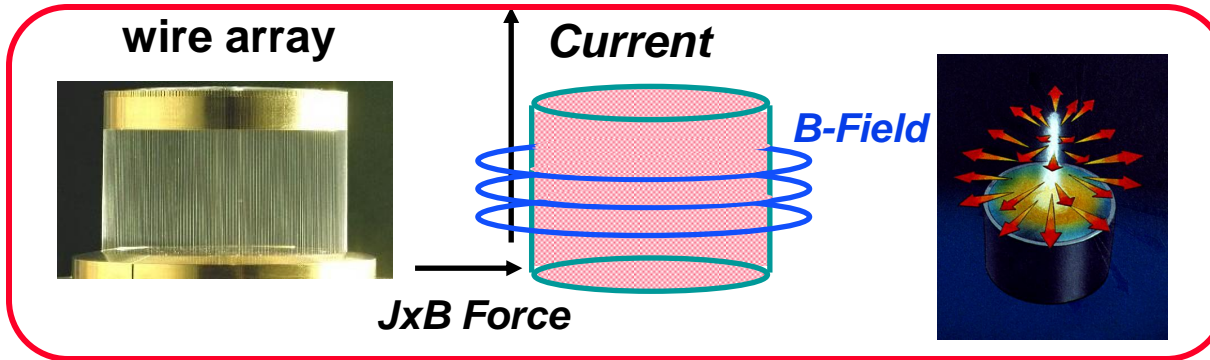



# Isentropic compression and shock wave experiments are both possible on Z

**Sample**  
 $P > 4$  Mbar

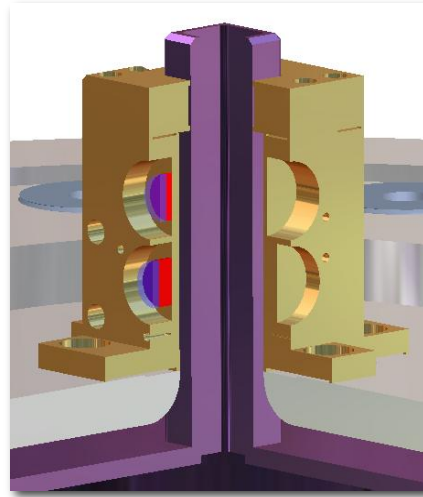
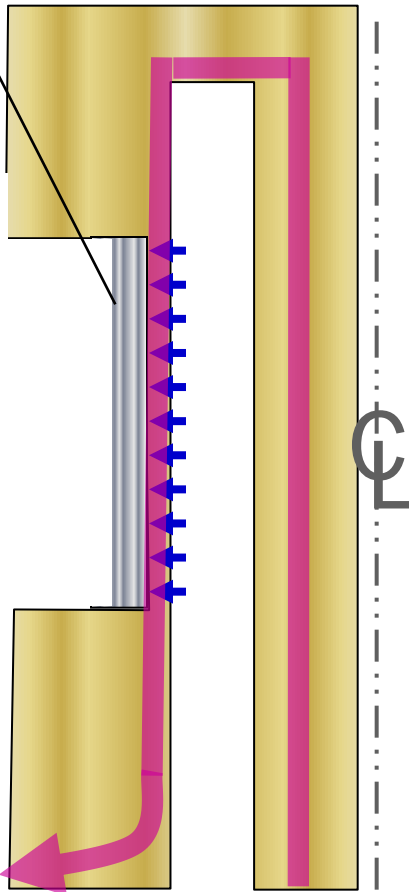

**Flyer Plate**  
 $v$  up to 40 km/s

**Sample**  
 $P > 10$  Mbar

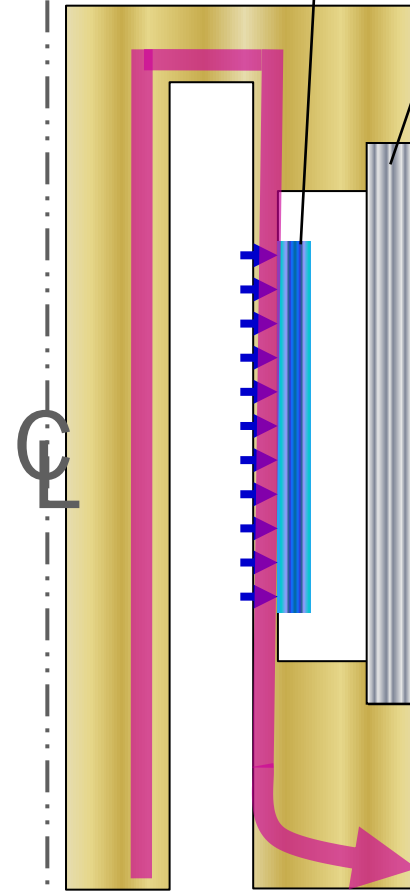

Isentropic Compression Experiments:  
gradual pressure rise in sample

Shock Hugoniot Experiments:  
shock wave in sample on impact





# Magnetic pressure can be used to examine fundamental material properties at HEDP conditions

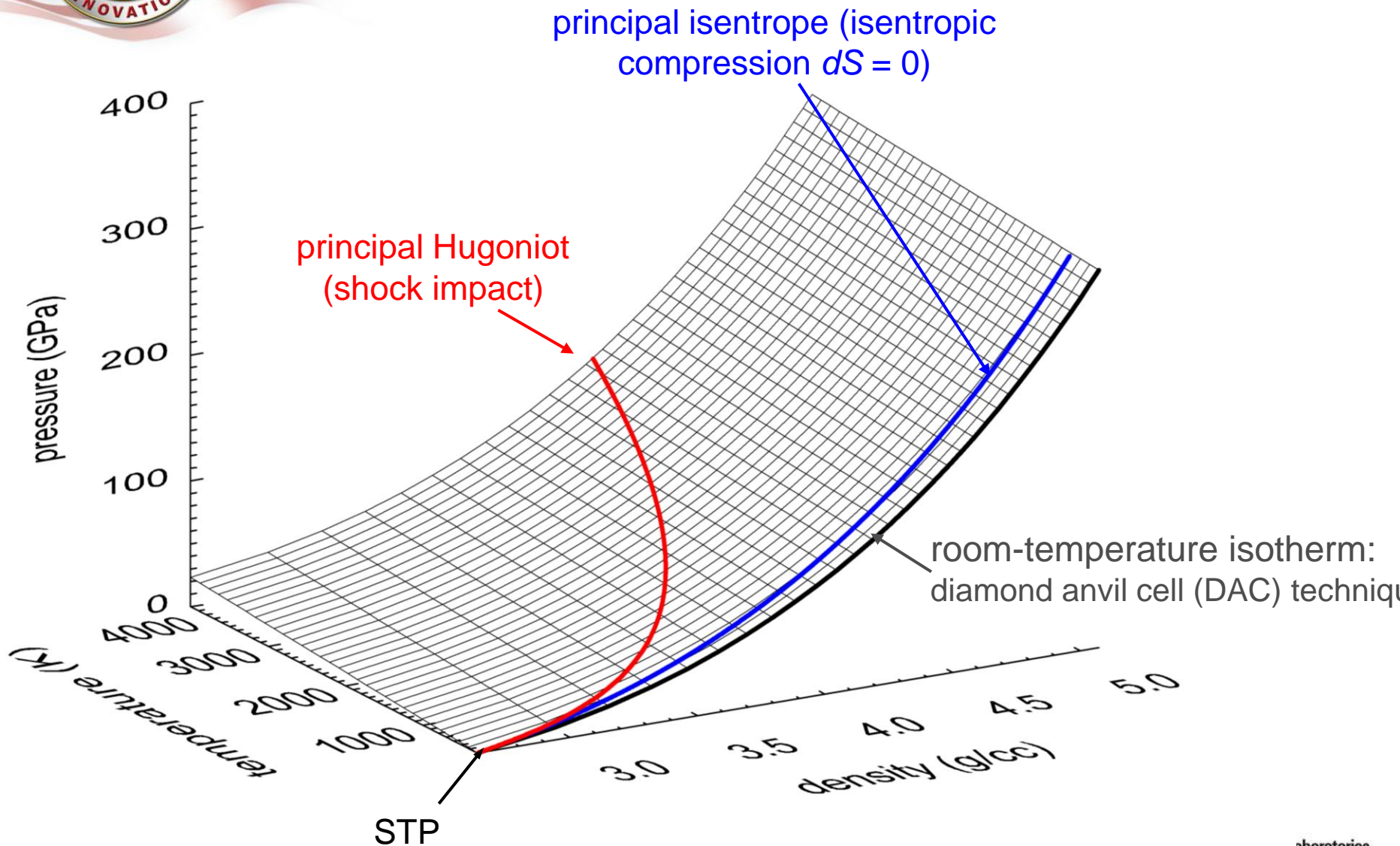



# Deuterium experiments demonstrated the capabilities of Z as a platform for accurate EOS measurements

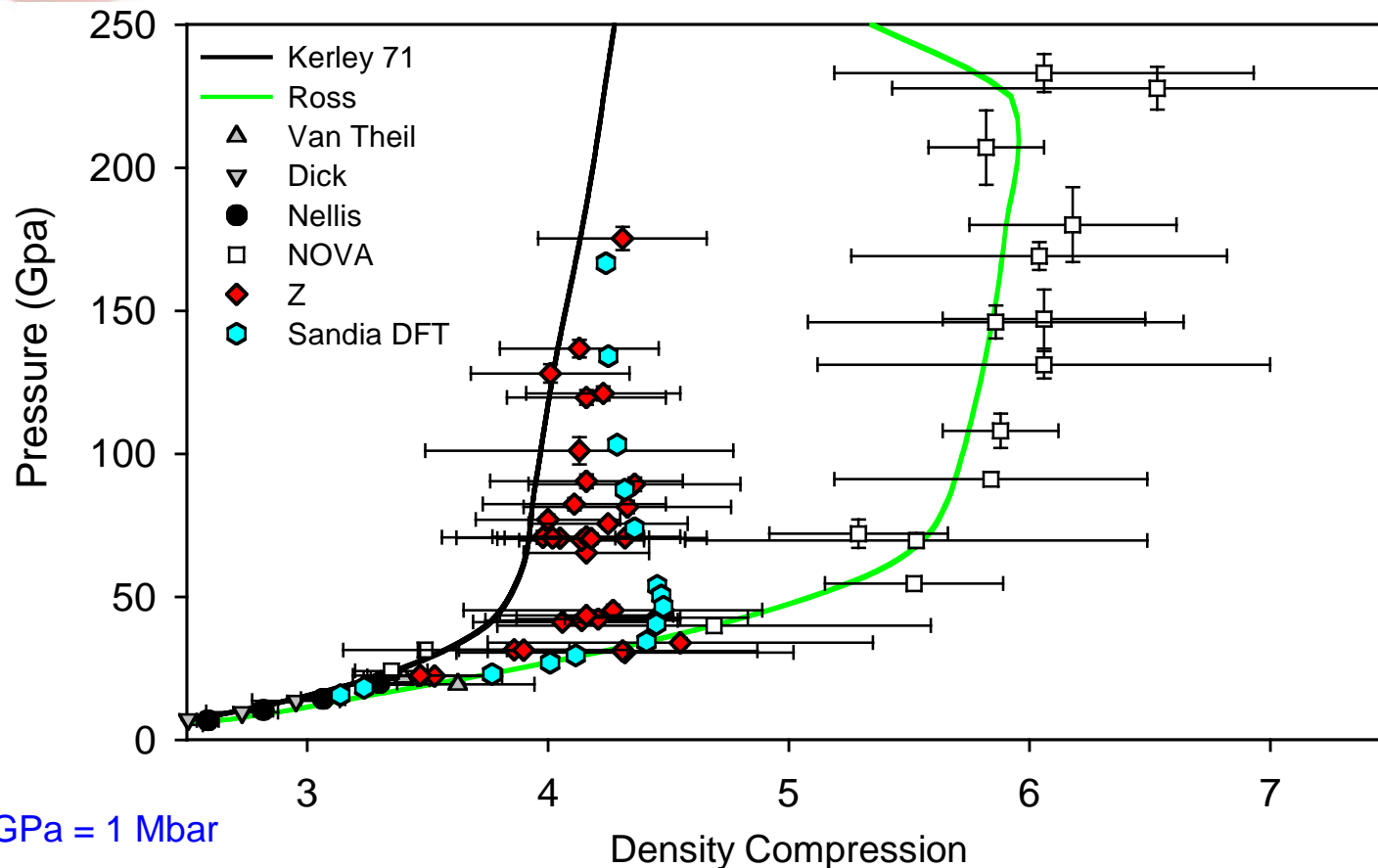

M. D. Knudson *et al.*, Phys. Rev. Lett. **87**, 225501 (2001)

M. P. Desjarlais, Phys. Rev. B **68**, 064204 (2003)

**Impacts ICF, primary physics, planetary models**



# Magnetically-driven fast Z-pinch implosions efficiently convert electrical energy into radiation

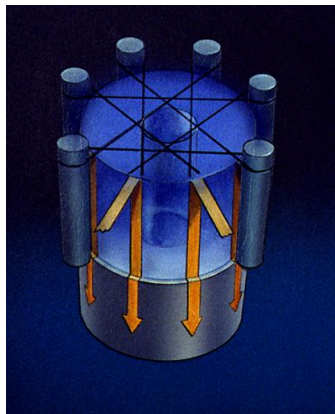
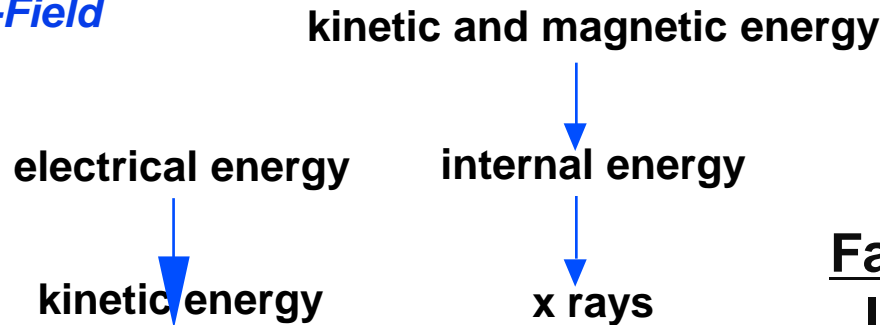
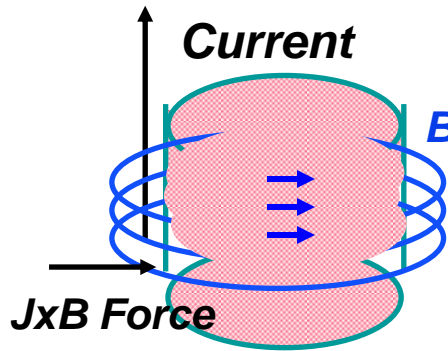

Ablation

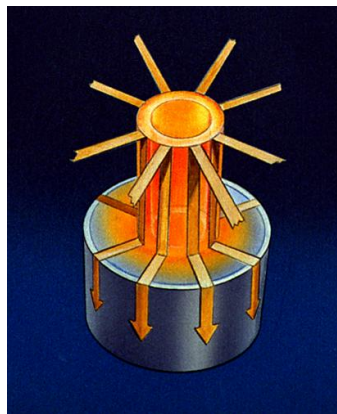

Implosion

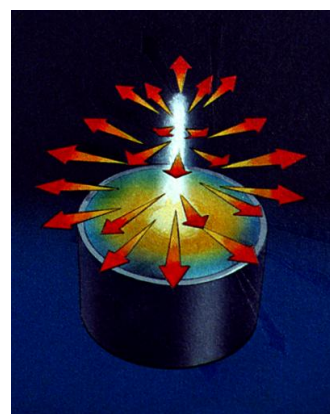

Stagnation

## Fast wire z-pinch loads:

- Z-pinchs are imploded in 60 to 120 ns
- Energy: x-ray  $\approx$  15% of stored electrical
- Power: x-ray  $\approx$  2-5 x electrical



# J x B force pinches wire array into a dense, radiating plasma column

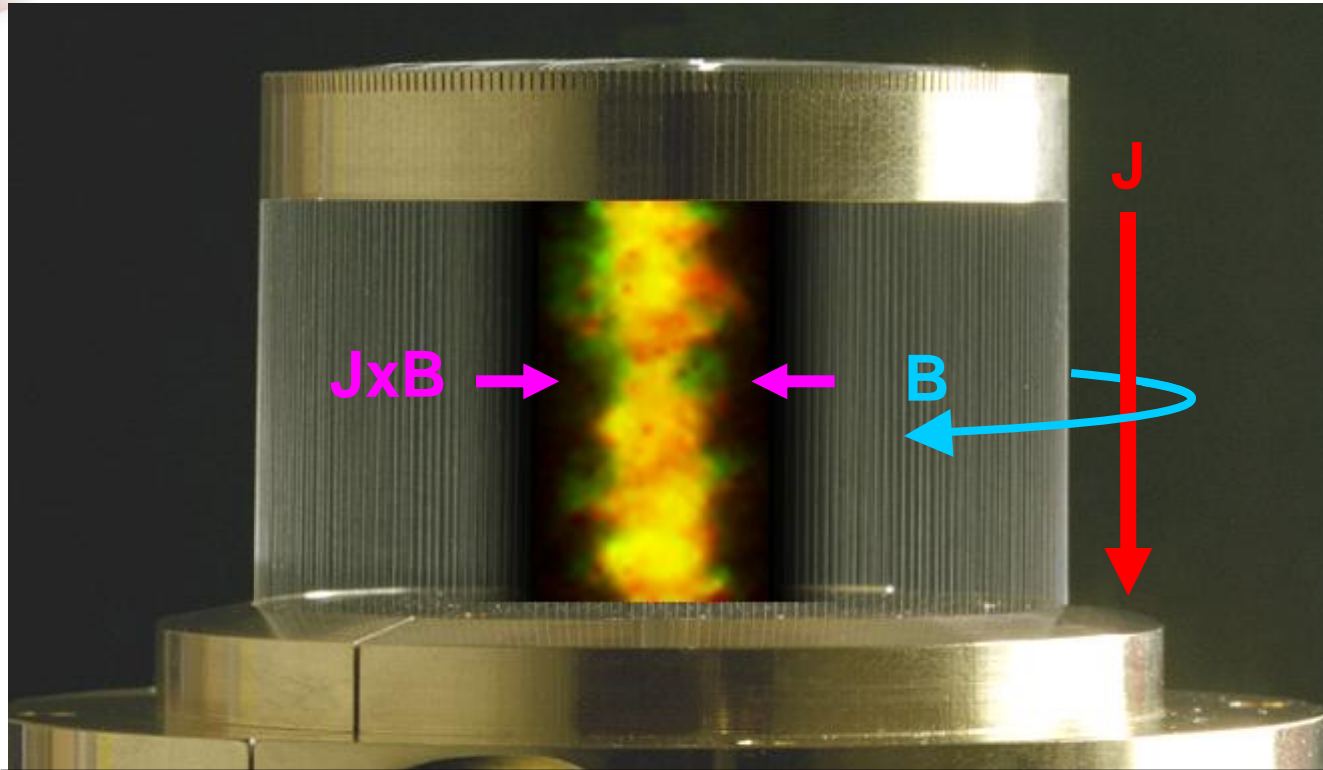

## z-pinch sources

$$n_i \sim 1 - 5 \times 10^{20} \text{ cm}^{-3}, Y_{\text{rad}} \sim 1 - 2 \text{ MJ}$$

$$P_{\text{rad}} \sim 100\text{-}250 \text{ TW} \sim 200 \text{ million million Watts}$$

$$T_{\text{rad}} \sim 200 \text{ eV} \sim 2,300,000 \text{ }^\circ\text{K}$$



# Z dynamic hohlraums are used to make opacity measurements for comparison with models

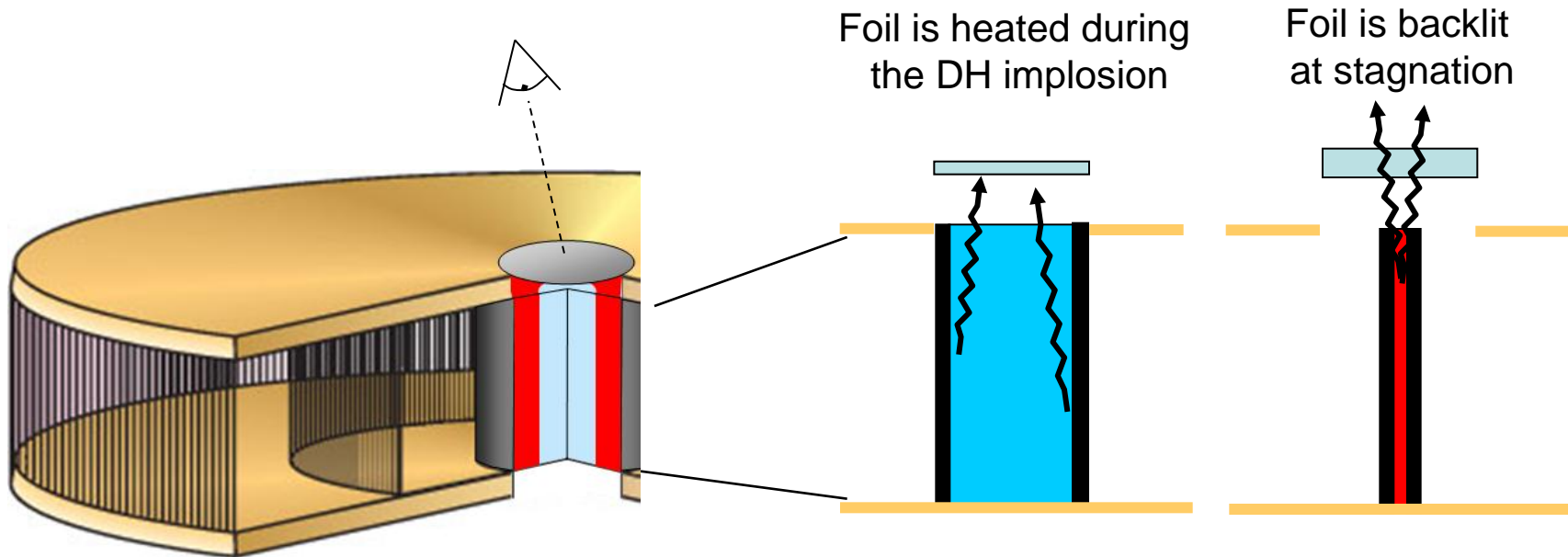

Fe transmission @  $T_e = 156$  eV

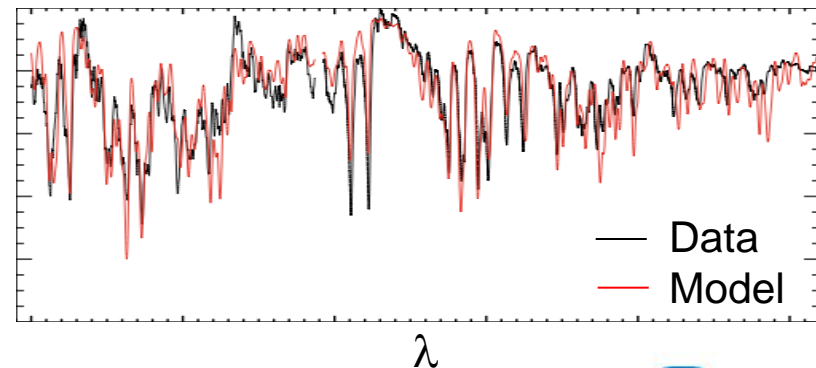

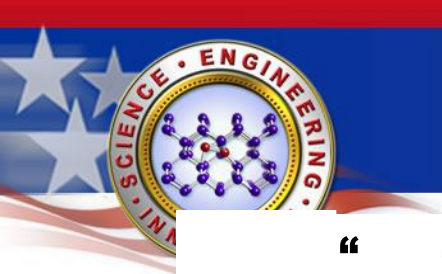

**“... the deep interior of the sun and stars is less accessible to scientific investigation than any other region of the universe....What appliance can pierce through the outer layers of a star and test the conditions within? ”**

**A.S. Eddington** *The internal constitution of the stars*

*Cambridge, 1926*



exterior observations \_\_\_\_\_

+

interior plasma property models

= understanding

**model reliability requires laboratory experiments**



# Z experiments test opacity models that are crucial for stellar interior physics

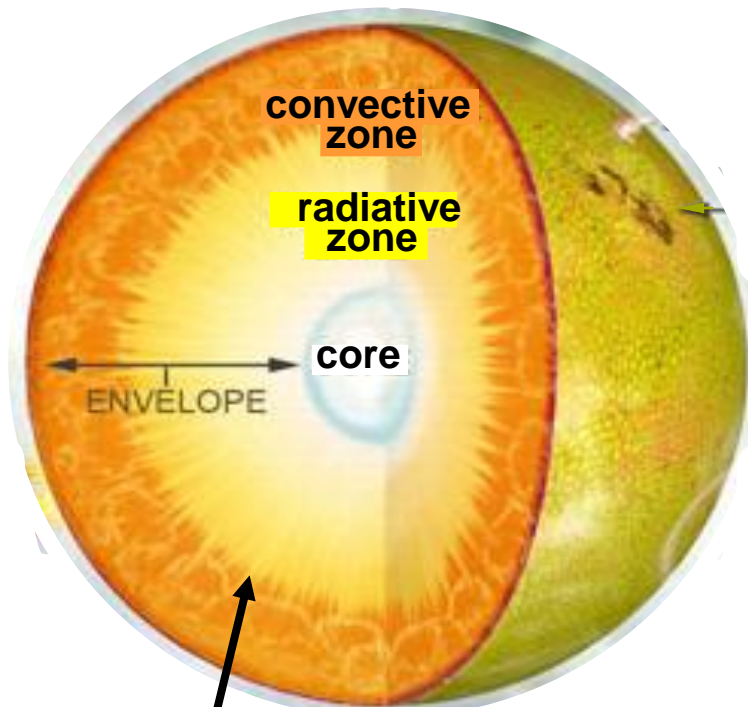

2007 Don Dixon / cosmographica.com

**Solar CZ boundary**  
**193 eV,  $1 \times 10^{23} \text{ cm}^{-3}$**

**Predictions of solar structure do not agree with observations**

**Solar structure depends on opacities that have never been measured**

**Challenge: create and diagnose stellar interior conditions on earth**

**High T enables first studies of transitions important in stellar interiors**



# Opacity measurements on Z are close to replicating solar interior matter

Mg K-shell absorption from a Mg/Fe foil

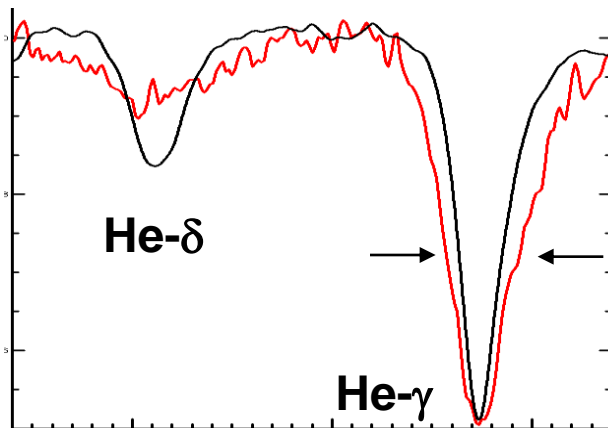
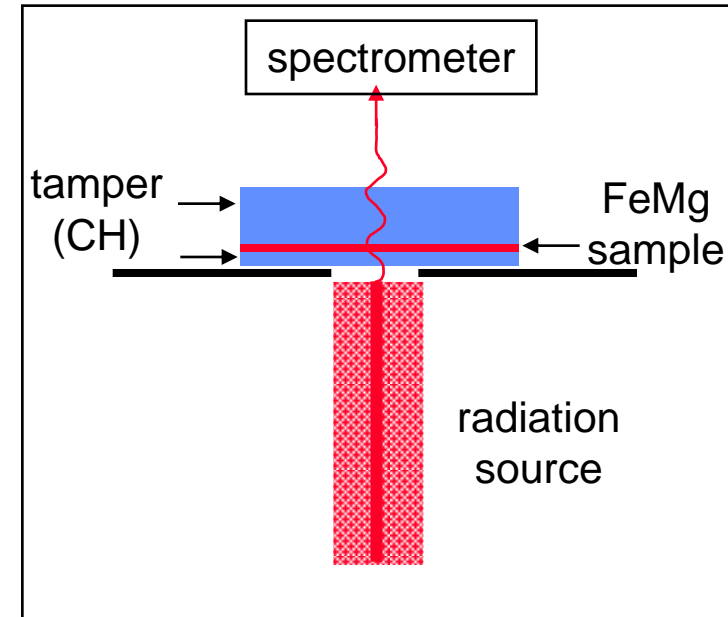
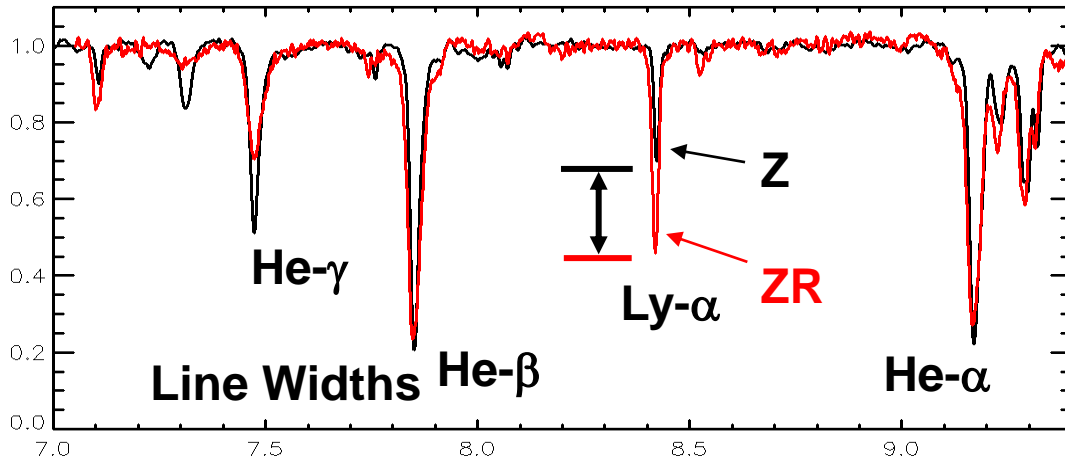

- Higher Ly/He ratios indicate ~20% increase in  $T_e$  ~190 eV
- Broader high-n lines indicate thicker tamper led to ~300% increase in  $n_e$

This is much closer to Fe conditions in the Sun





# $3.9 \times 10^{13}$ D-D neutrons have been produced in deuterium gas puff experiments on Z at 17.7 MA

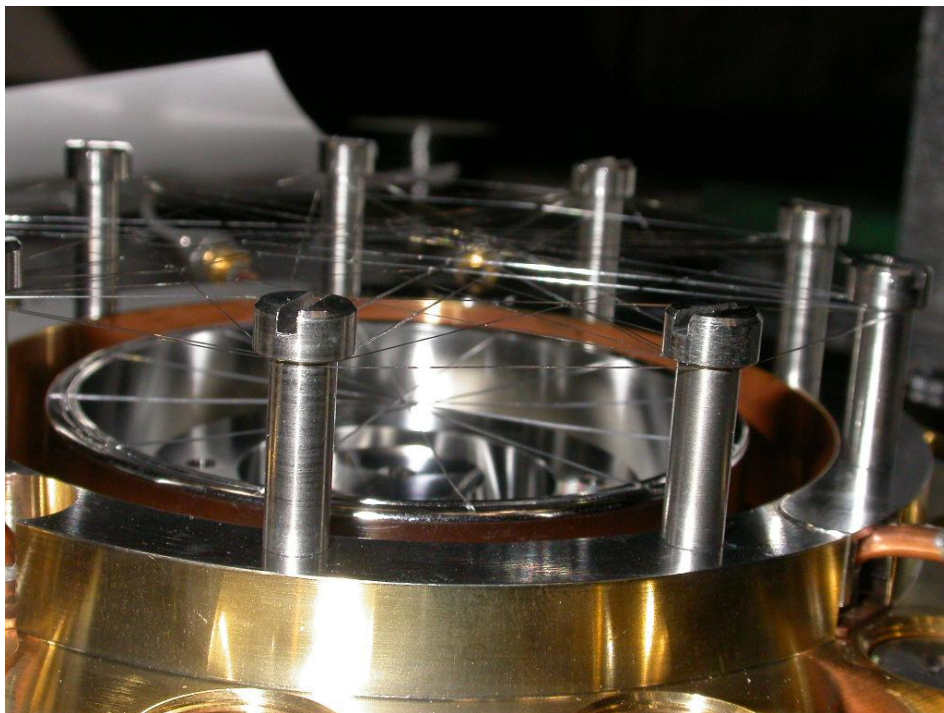

**Gas puff nozzle**

- **Yield follows approximately  $I^4$  scaling**
  - **In agreement with previous assessments for neutron scaling from pinch systems**
- **Origin of these neutrons is still being assessed experimentally**
- **1D, 2D, and 3D MHD calculations reproduce measured outputs**
- **Particle In Cell (PIC) calculations of this system are revealing new insights into this system**

**C. A. Coverdale, C. Deeney et al., Phys. Plasmas 14, 022706 (2007)**

**A. L. Velikovich et al., Phys. Plasmas 14, 022701 (2007)**



# PIC calculations provide insight to the 50 year old issue of the neutron production mechanism in Z-pinch plasmas

- Neutron production scaling as  $I^4$  is quite promising\*
- Deuterium Z-pinch systems have been examined experimentally for many years
  - Significant neutron production is observed
  - **Early conclusions had been that the majority of neutron yield is from non-thermal deuterium population that does not scale favorably**
- Fully kinetic electromagnetic modeling is now possible that includes both nonthermal and thermal processes to address this fundamental issue
- Recent PIC calculations of this fundamental plasma system are providing new understanding in how neutrons are produced in pinched plasma systems
- Recent Publications:
  - D. R. Welch et al., Phys. Rev. Lett. 103, 255002 (2009)
  - D. R. Welch et al., Phys. Plasmas 17, 072702 (2010)
  - D. R. Welch et al., Phys. Plasmas 18, 056303 (2011)

\*J. Ise, Jr. and R. V. Pyle, in Conference on Controlled Thermonuclear Reactions, Princeton Univ., 17-20 October 1955 (TID-7503, USAEC, 1955), p.218; Velikovich, et al. Phys. of Plasmas 14 022701 (2007).



# Particle-in-cell (PIC) modeling is a natural way to describe Z-pinch plasmas

Particle currents,  $n$ ,  $v$ , interpolated to grid; fields back to particles

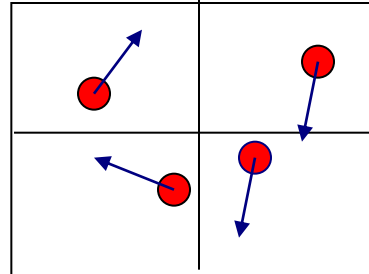

EM Fields, pressure, etc. calculated on grid

- **PIC follows macroparticles with each representing many real ones**
  - Particle currents  $J$  (or charges  $\rho$ ) are interpolated to a grid
  - Maxwell's (or Poisson's) equations are advanced on the grid using  $J$  or  $\rho$
  - The electric  $E$  and magnetic  $B$  fields are interpolated to particles
  - The particle momentum  $p$  and position  $x$  are advanced with new  $E$  and  $B$

D. R. Welch, D. V. Rose, W. A. Stygar, and R. J. Leeper, "Electromagnetic Kinetic Simulations of a Deuterium Gas Puff Z-pinch", 36th International Conference on Plasma Science, San Diego, CA, June 3, 2009.



# Kinetic PIC model of a D Z-pinch is revealing physics not seen in MHD calculations

## 2D 15 MA LSP simulation

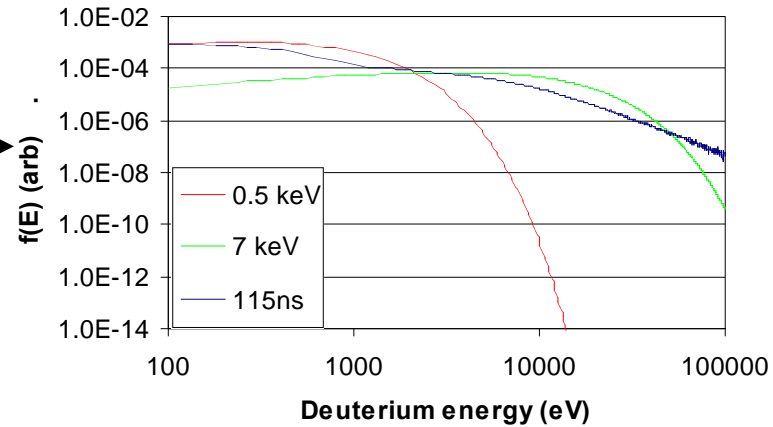
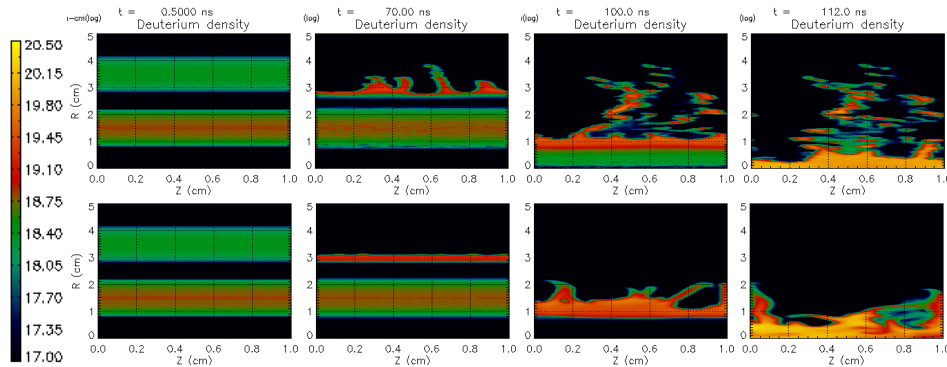

## 2D 15 MA MHD (Mach2) simulation

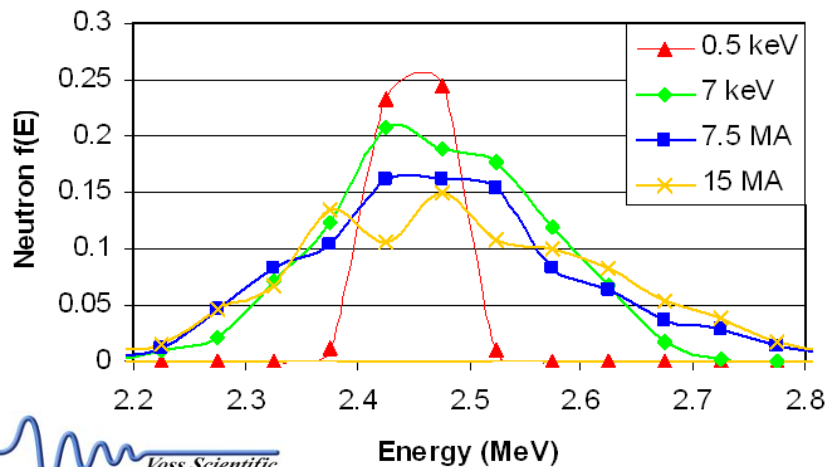

High energy tail accounts for half neutron production by 115 ns, broadens neutron energy spectrum.

Favorable neutron yield production with pinch current!

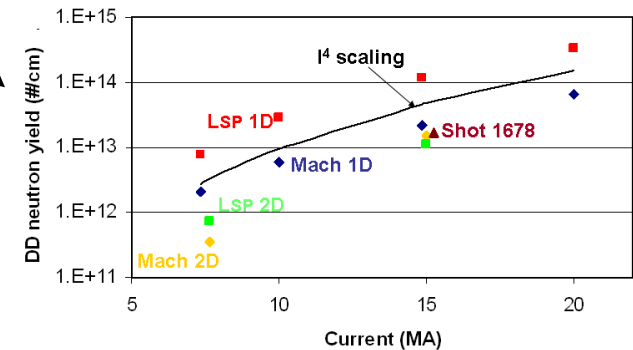



# Neutron spectrum reflect higher reactant energies as pinch progresses

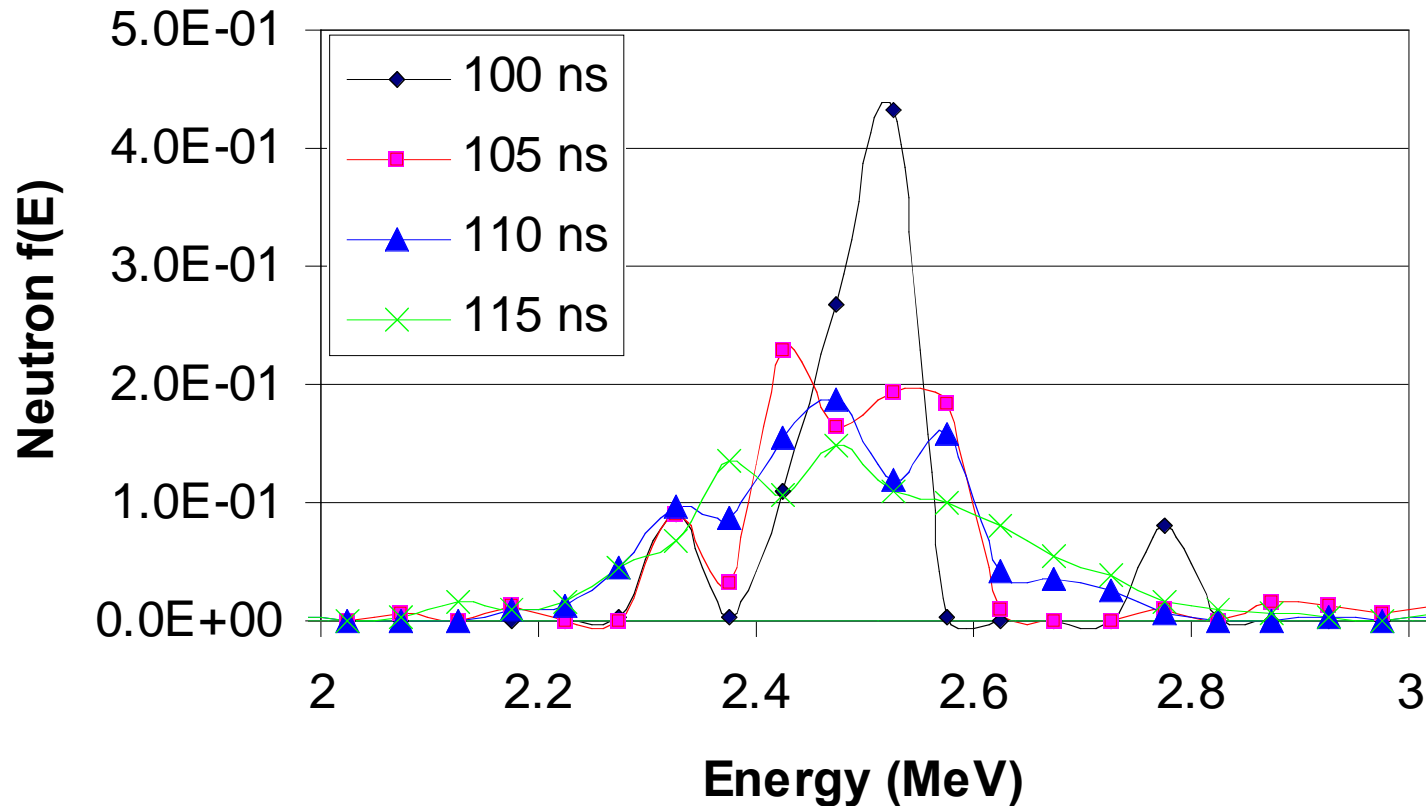

- FWHM of distribution increases from 80 to 300 keV
- These neutron spectra suggest that both “thermal” and “non-thermal” neutrons are produced in pinch plasma systems

# Combined MHD and PIC simulations model implosion, particle acceleration and fusion reaction kinetics

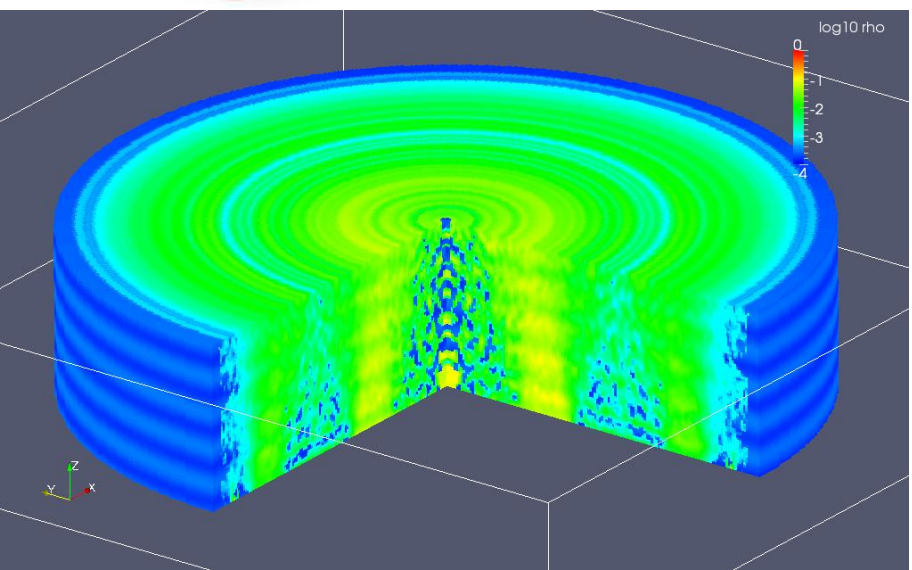

MHD code of gas puff Z-pinch on Z, using measured deuterium density profile plus 3D helical twist thermonuclear yield of  $4 \times 10^{13}$  D-D

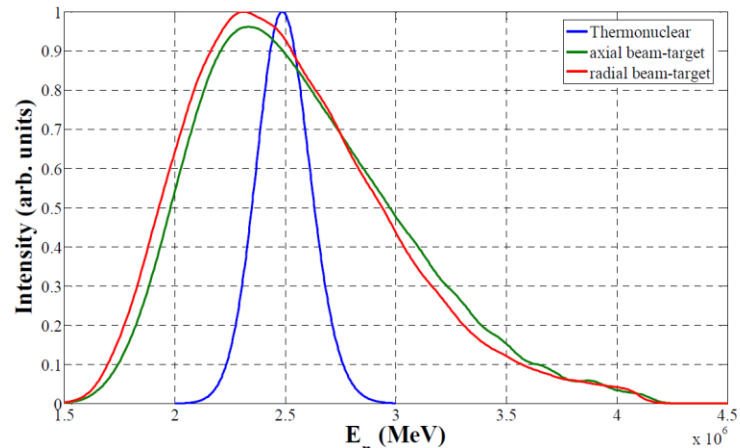
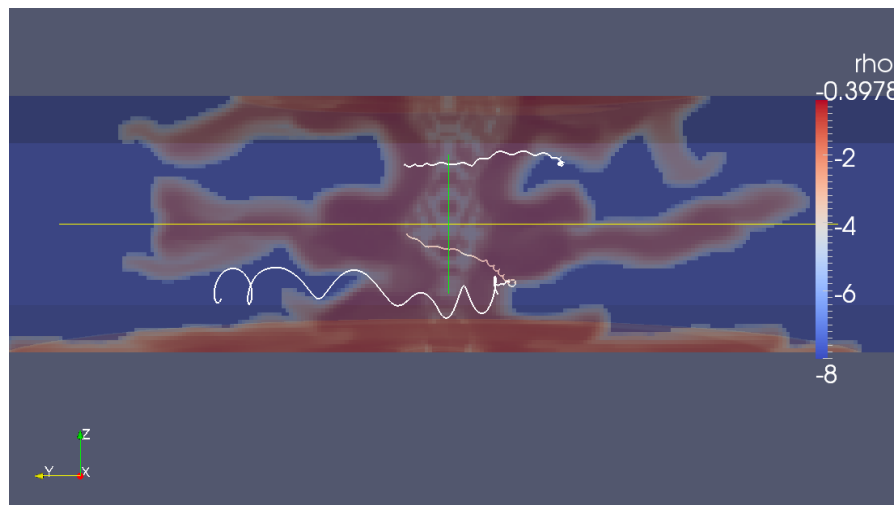

Neutron spectrum is dominated by thermonuclear reactions, but has a broad range of energies due to accelerated and magnetized beam of deuterons



# Similar combined MHD & PIC techniques are being used to model liner fusion schemes such as MagLIF

## Magnetization

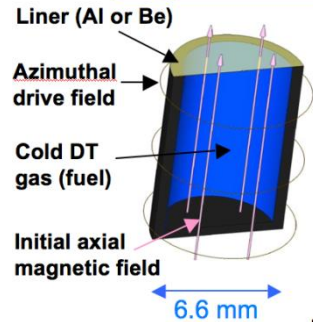

## Preheat

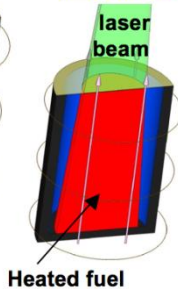

## Compression

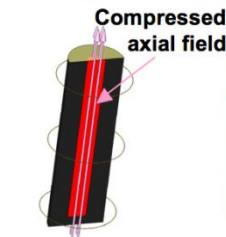

S.A. Slutz et al., Phys. Plasmas 17, 056303 (2010)

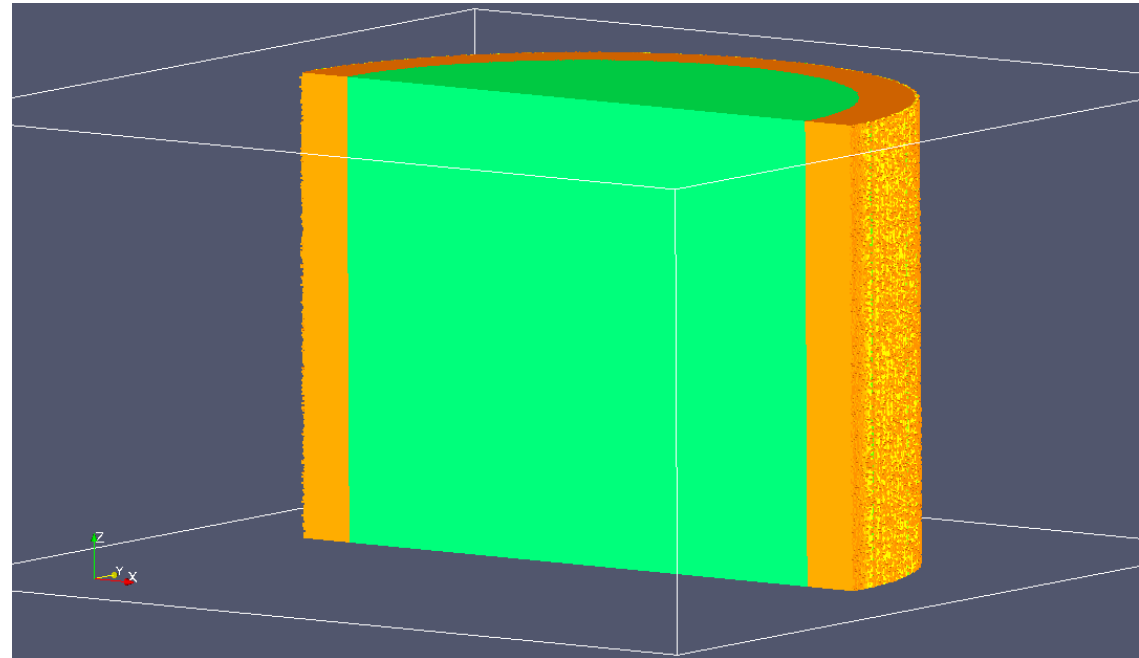

Rayleigh Taylor instability grows in the aluminum liner during implosion, but is unable to penetrate into fuel before a fusion yield of 100 kJ is obtained

Unique explicit formalism of Imperial College's MHD code 'Gorgon' enables efficient parallel scaling - demonstrated on up to 13,000 processors on AWE's Blackthorn computer - with  $13 \times 10^9$  computational elements in simulations of SNL wire arrays and liner fusion schemes



# DD and DT associated particle neutron calibration facility located at Sandia's Ion Beam Laboratory

**350 keV Cockcroft-Walton**



**Dedicated beam-line and hardware**

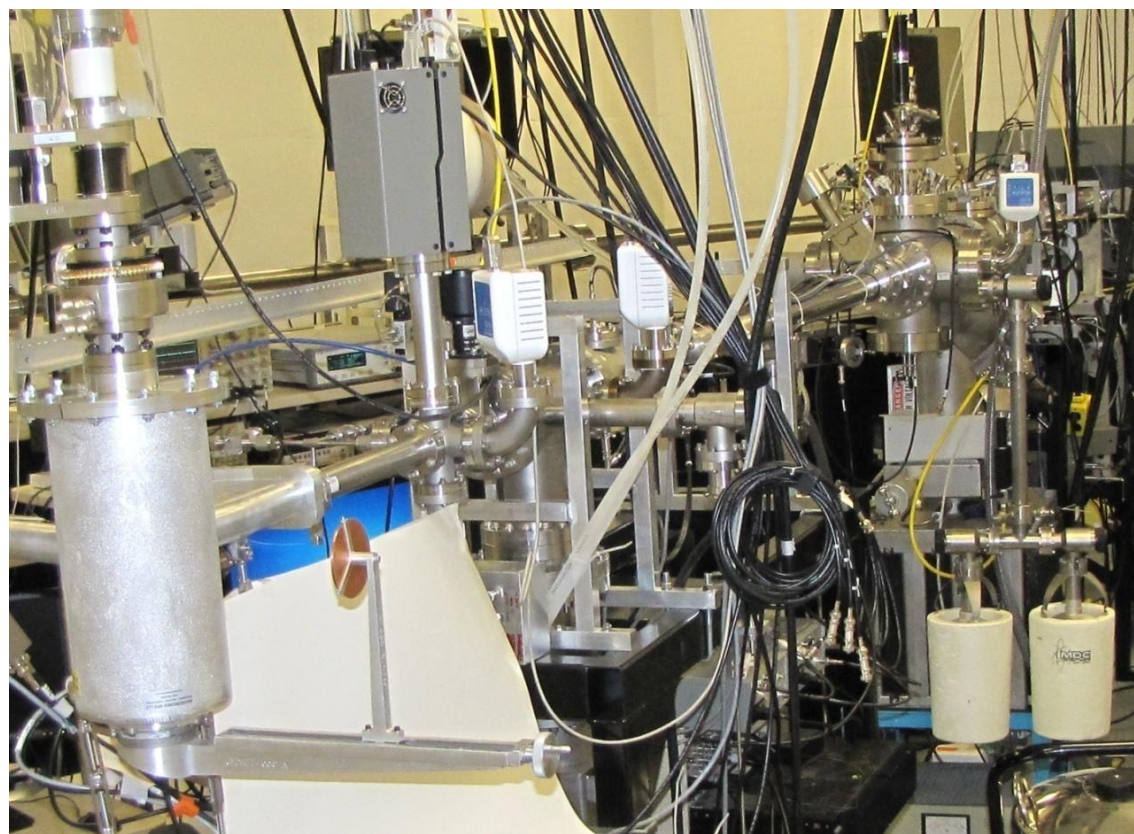

**Data acquisition setup**

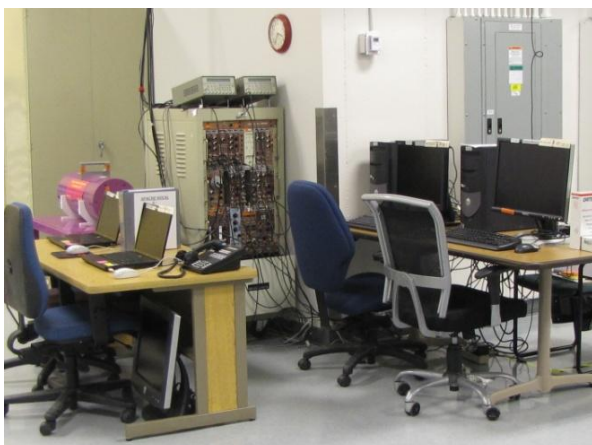





# Associated-particle technique employs the measurement of charge particle emission from DD and DT reactions

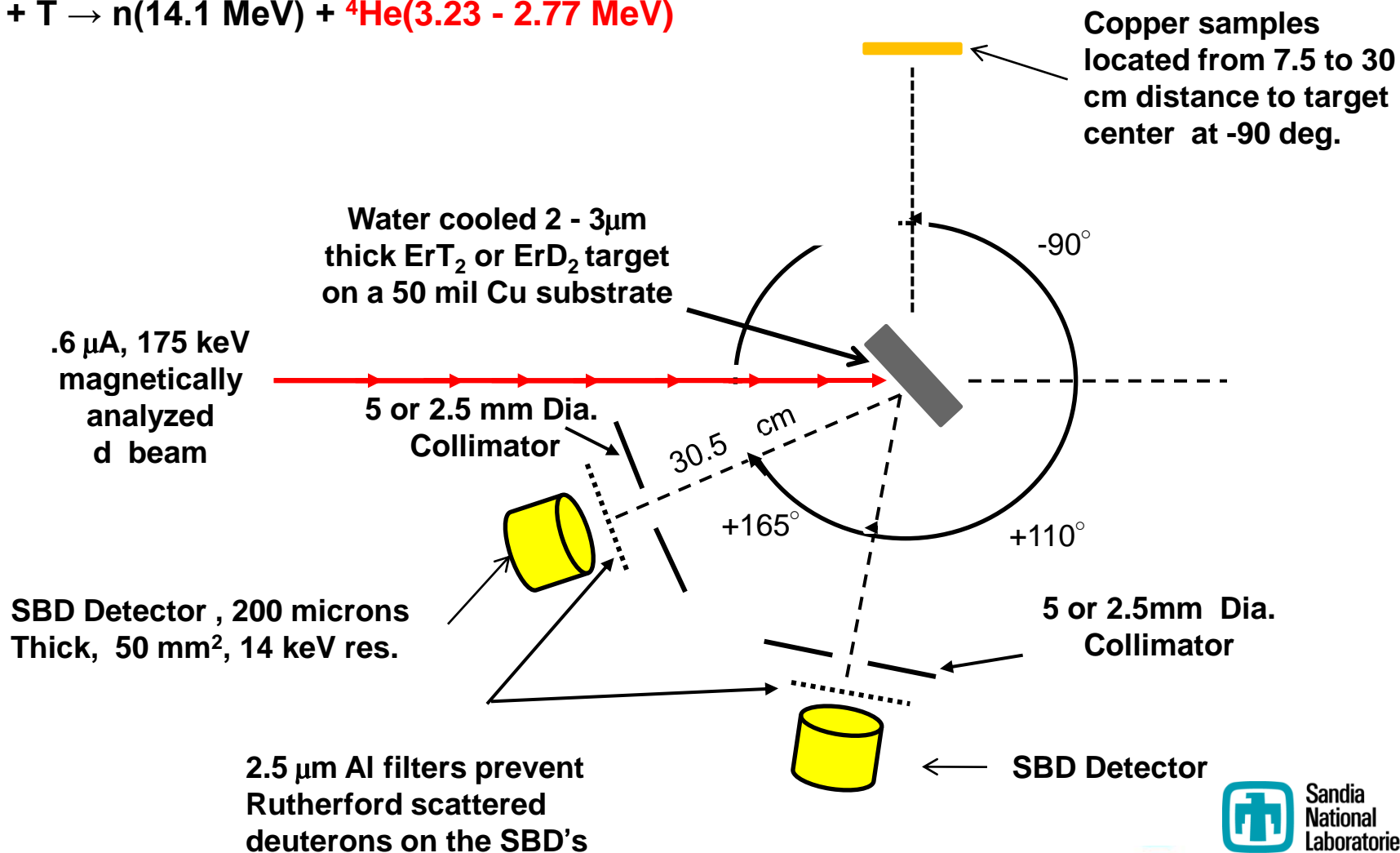
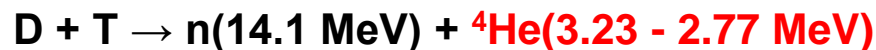



# It's an exciting time to be working on the Z facility

- **Refurbished Z is up and running**
- **Ever more extreme conditions are being reached in the dynamic materials program**
- **Several new concepts for pulsed power inertial confinement fusion look interesting**
- **Higher currents are enabling brighter x-ray sources and hotter and denser plasmas for astrophysical opacity research**
- **Particle In Cell (PIC) calculations of a gas puff Z-pinch reveal new insights into this “classic” plasma system**



# We are developing new pulsed power architectures for a next generation z-pinch facility

$$E_{\text{stored}} = 180 \text{ MJ}$$

$$V = 24 \text{ MV}$$

$$P_{\text{electrical}} = 1100 \text{ TW}$$

$$I = 68 \text{ MA}$$

$$L = 29 \text{ nH}$$

$$\tau_{\text{implosion}} = 95 \text{ ns}$$

$$\eta_{\text{electrical}} = 70\%$$

$$\text{diameter} = 100 \text{ m}$$

W. A. Stygar, *et. al.*, "Architecture of petawatt-class z-pinch drivers", *Phys. Rev. ST Accel. Beams* 10, 03040 (2007)

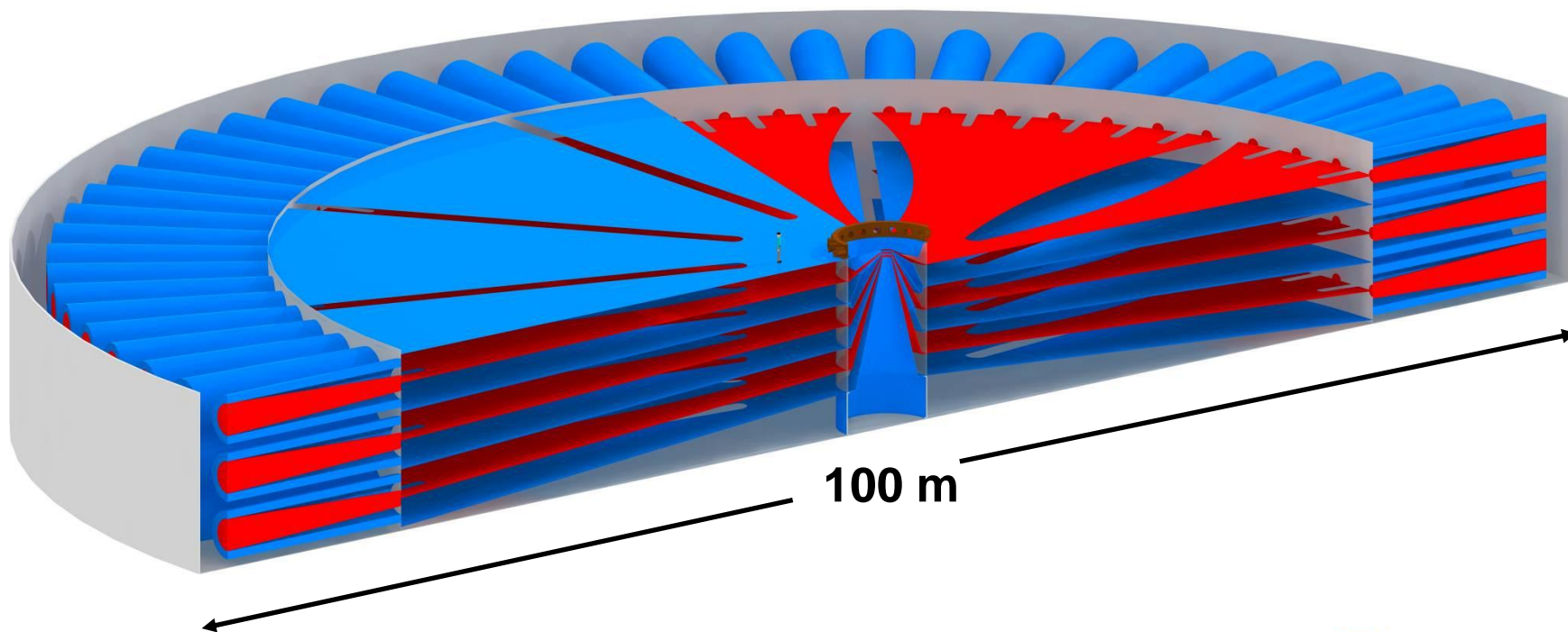



# Several recent studies have highlighted High Energy Density Science

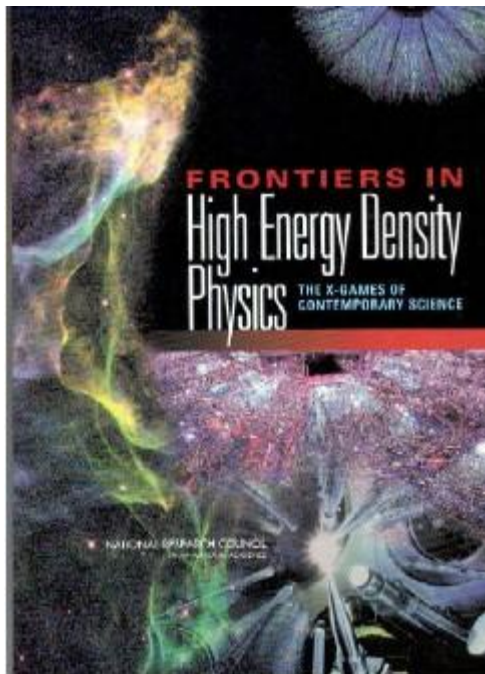

**“Frontiers in High Energy Density Physics”,  
R. Davidson et al. 2004**

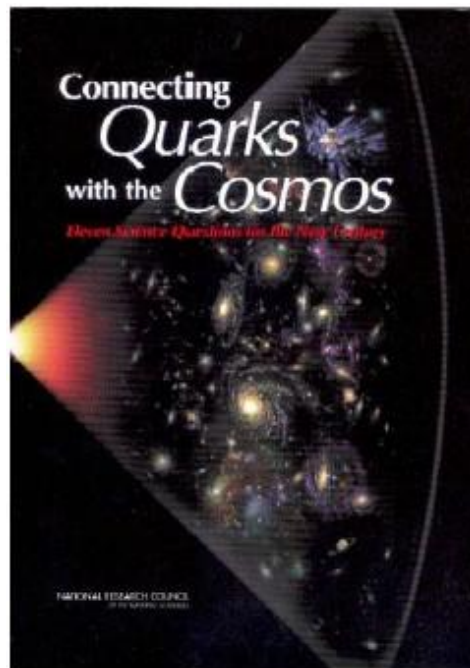

**“Connecting Quarks with the Cosmos: Eleven Science Questions for the New Century”,  
M Turner et al. 2002**

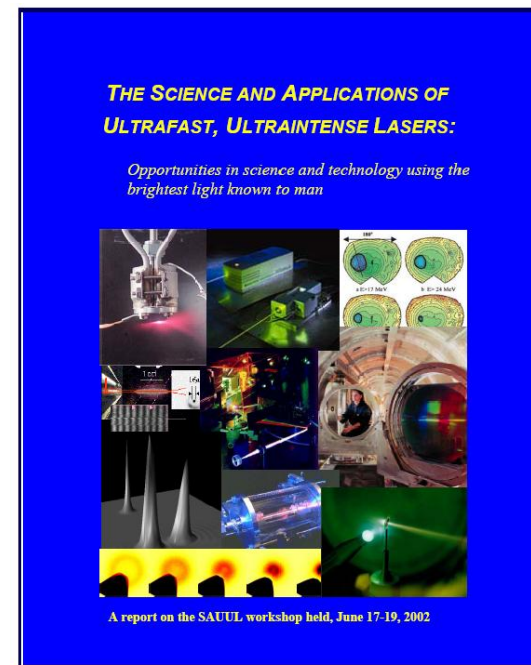

**Science and Applications of Ultrafast, Ultraintense Lasers (SAUUL)**



# The five-year Z-Re refurbishment project has been completed

**Last Shot**

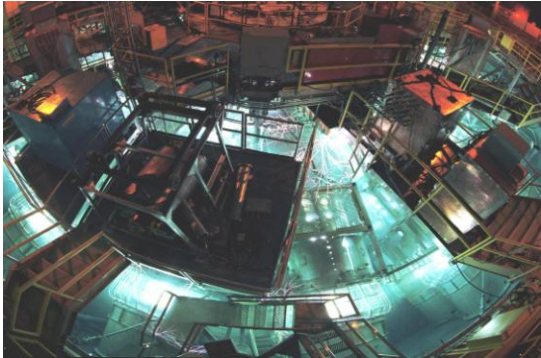

**July '06**

**Demolition Completed**



**Sept '06**

**Tank Modifications Completed**



**Jan '07**

**Installation Underway – Multiple Contractors**



**March '07**

**Installation Completed**



**August '07**



# Our MHD simulation capability is a powerful design tool

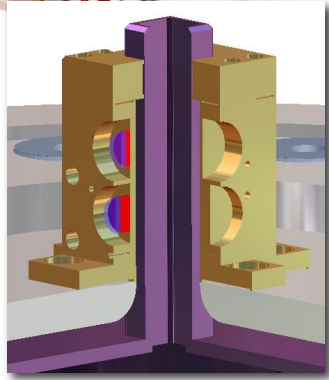

DFT based material models gave us predictive capability  
ASC codes enable optimized experiments

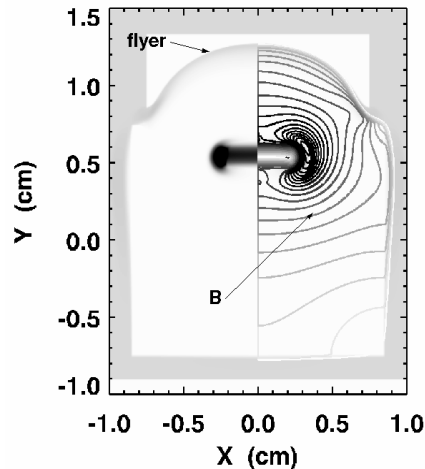
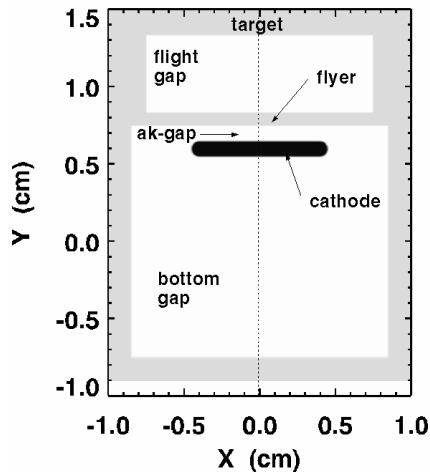

Measured / predicted current & flyer velocity (850  $\mu\text{m}$  Al)

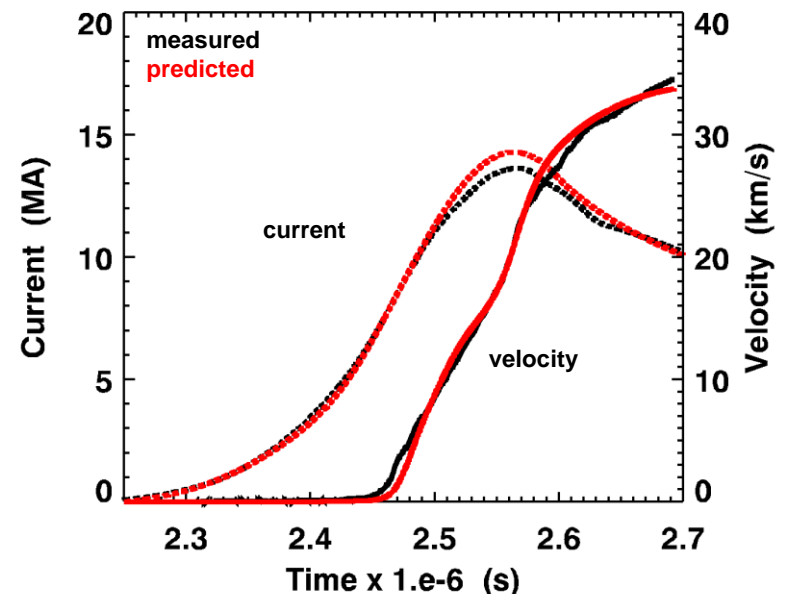

R. W. Lemke *et al.*, *J. Appl. Phys.* **98**, 073530 (2005)

In 2-D,  $10^6$  elements, 160 CPUs, 4 hours (T-Bird)

In 3-D, up to  $10^8$  elements, 8192 CPUs, 300 hours (ASC Purple)



# Magnetic pressure can be used to examine fundamental material properties at HED conditions

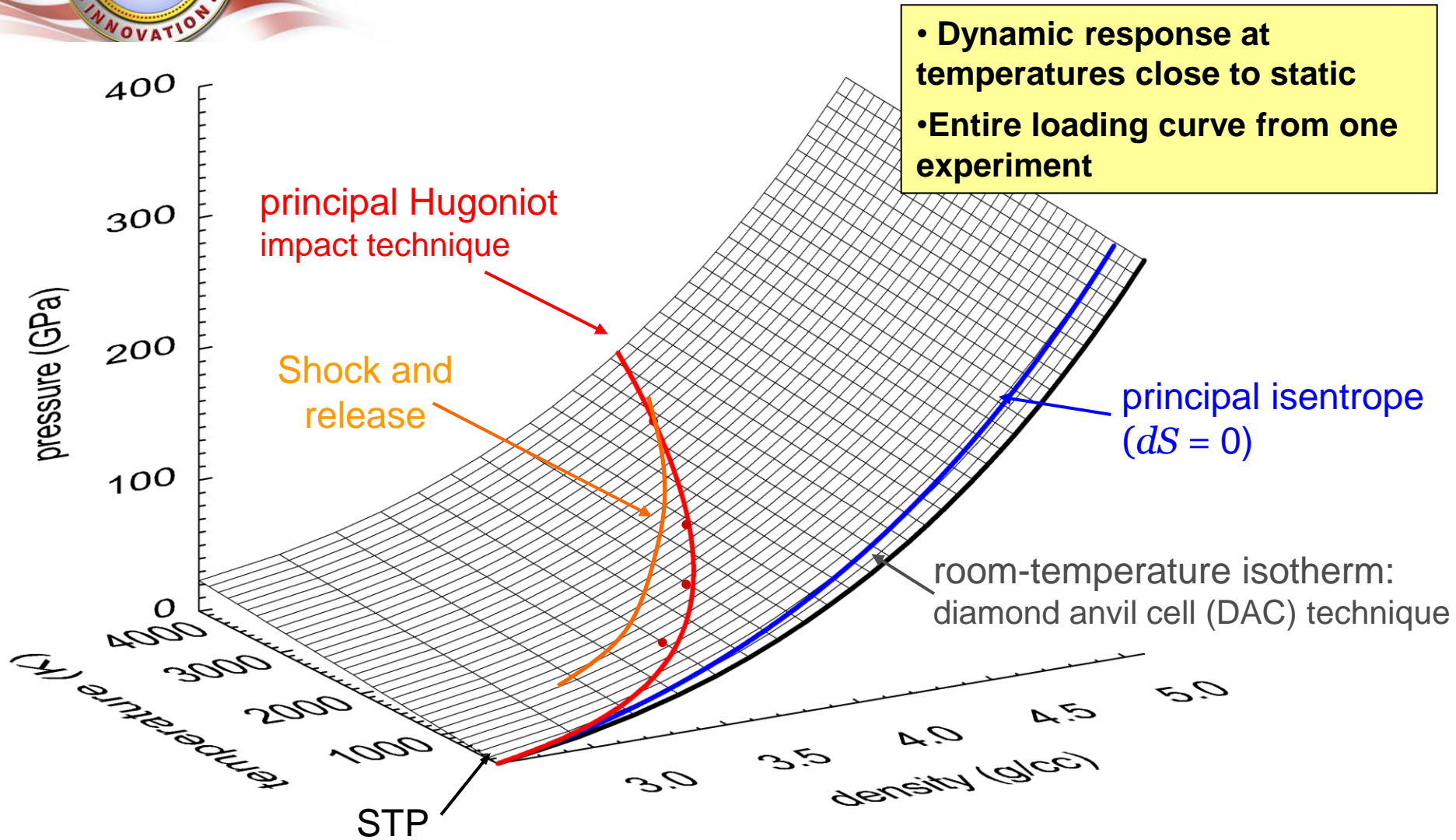



# It's an exciting time to be working on the Z facility

- Refurbished Z is up and running
- Ever more extreme conditions are being reached in the dynamic materials program
- **Several new concepts for pulsed power inertial confinement fusion look interesting**
- Higher currents are enabling brighter x-ray sources and hotter and denser plasmas for astrophysical opacity research
- Particle In Cell (PIC) calculations of a gas puff Z-pinch reveal new insights into this “classic” plasma system





# It's an exciting time to be working on the Z facility

- **Refurbished Z is up and running**
- **Ever more extreme conditions are being reached in the dynamic materials program**
- **Several new concepts for pulsed power inertial confinement fusion look interesting**
- **Higher currents are enabling brighter x-ray sources and hotter and denser plasmas for astrophysical opacity research**
- **Particle In Cell (PIC) calculations of a gas puff Z-pinch reveal new insights into this “classic” plasma system**



# Dynamic hohlraums efficiently couple x-rays to capsules

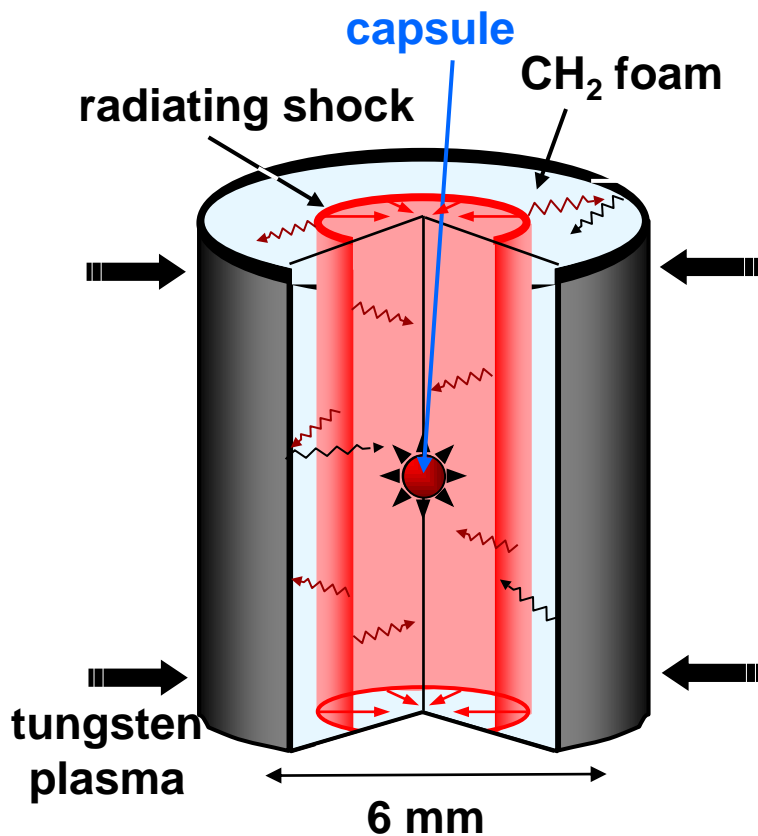

- Z-pinch plasma impacts foam converter
- The impact launches shocks in foam and tungsten
- The foam shock is a main radiation source
- The z-pinch confines the radiation
- Capsule heated mainly by re-emission from tungsten hohlraum wall

## physics issues:

1. interior diagnostics
2. symmetry
3. radiation production
4. radiation transport
5. radiation confinement
6. preheat



# Dynamic hohlraums drive capsule implosions with 180-220 eV drive radiation temperature

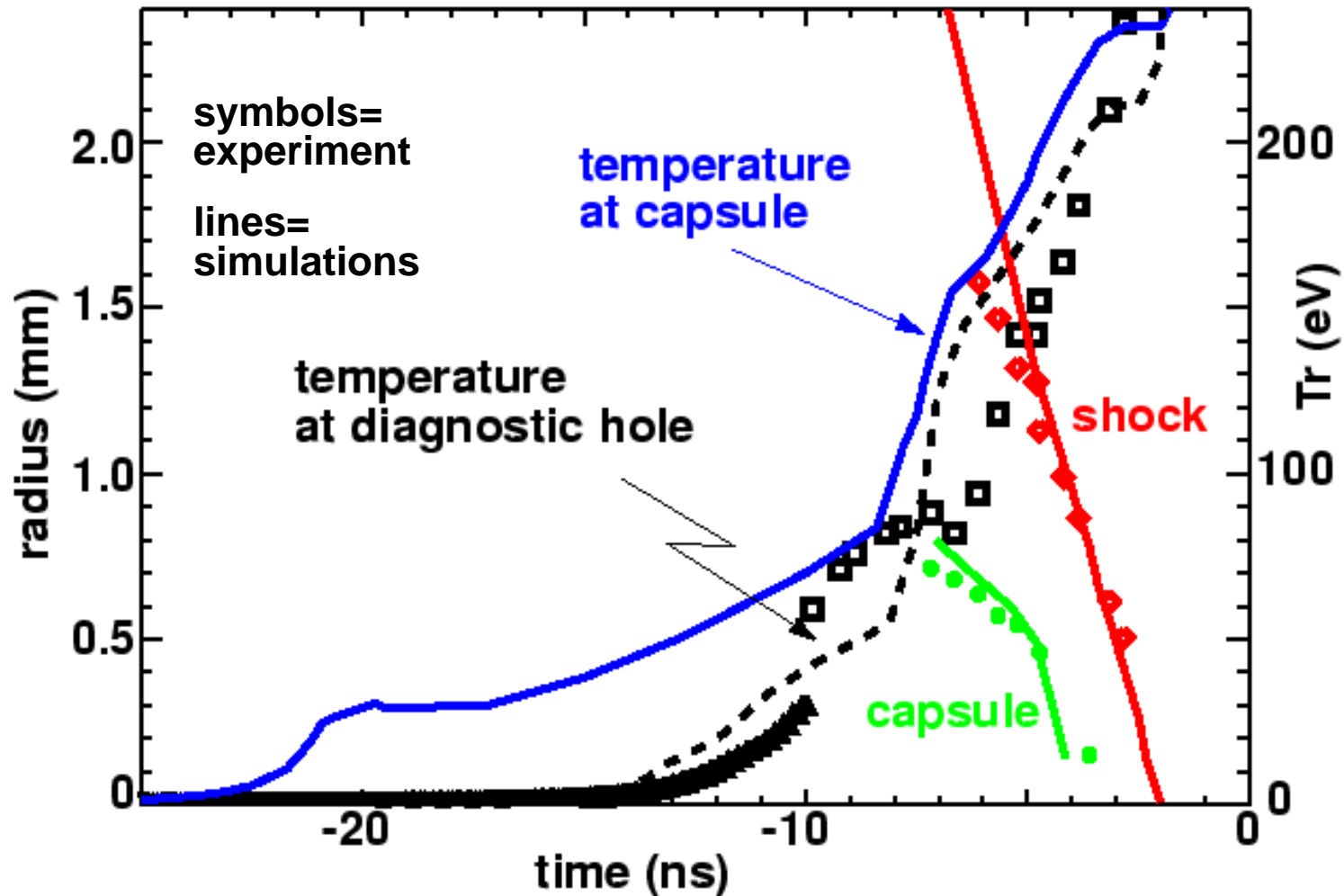



# Schematic of the neutron diagnostic arrangement used in these capsule experiments is shown here

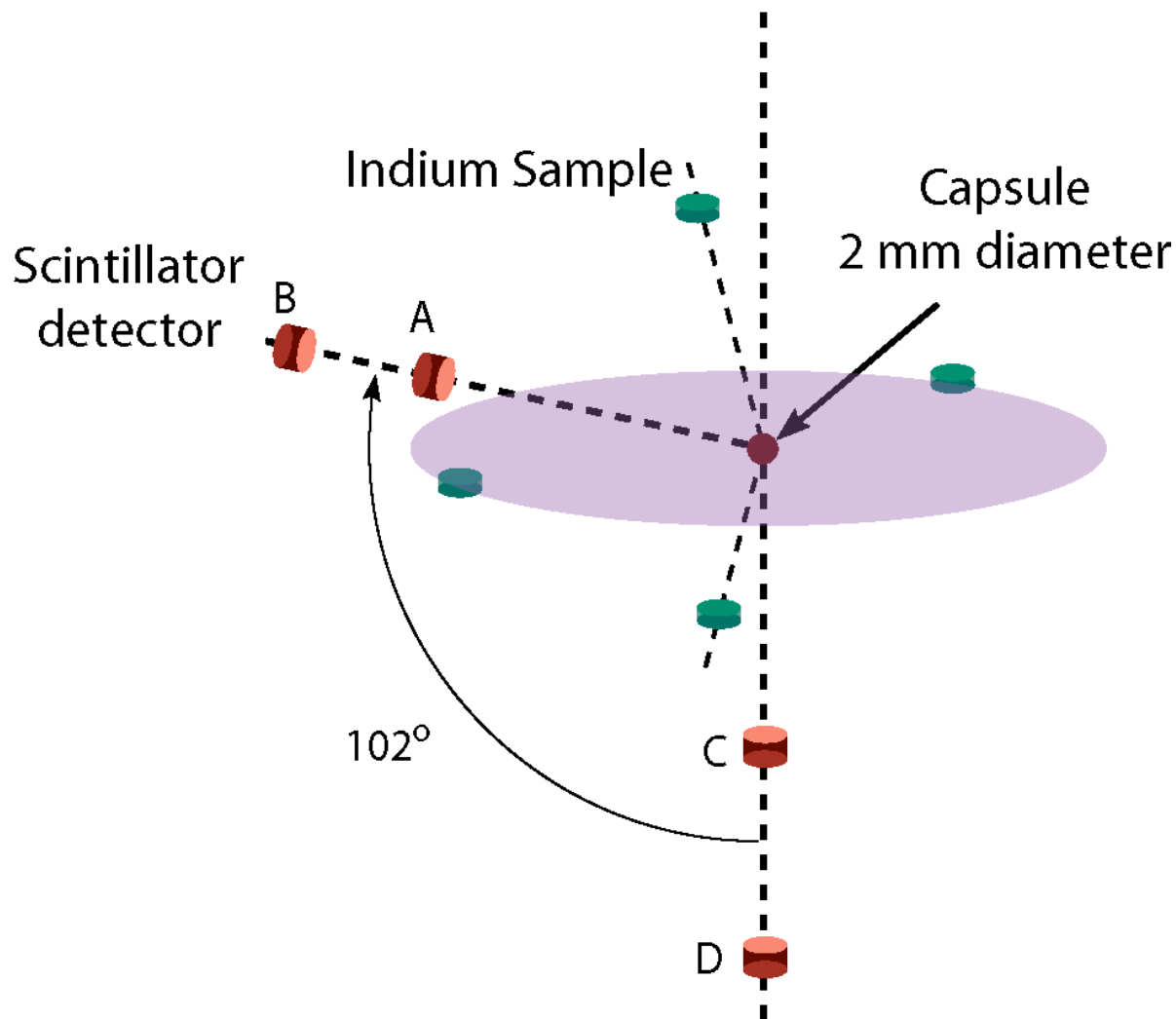



# Side-on neutron time-of-flight data showing the detection of DD neutrons on a Be capsule shot

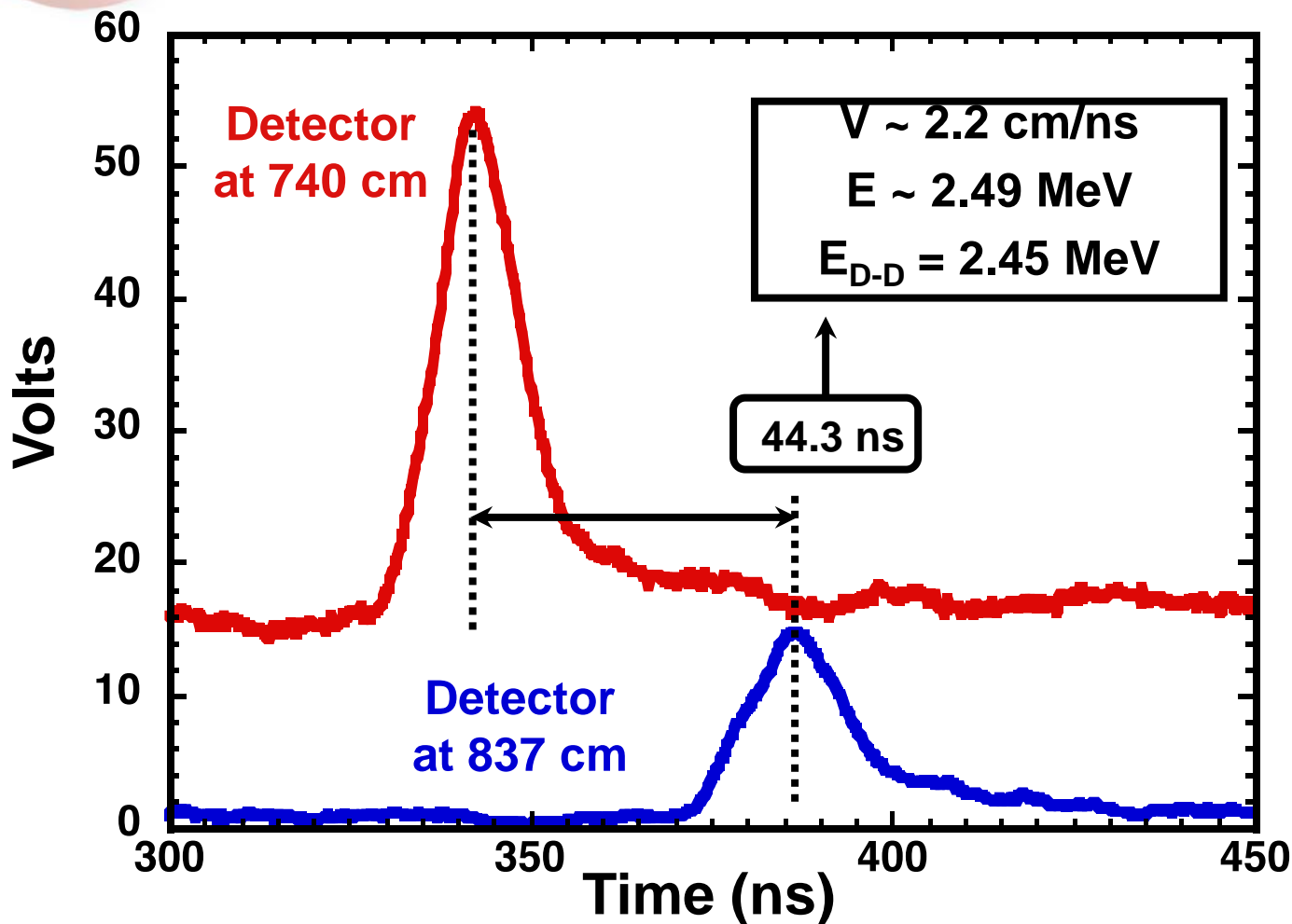

Data from 2-mm Be capsule with 33- $\mu\text{m}$  Be wall on 18- $\mu\text{m}$  plastic filled with  $\sim 16$  atm DD



# Neutron time-of-flight signal dramatically decreases when Xe fill gas is added to “null” the production of thermonuclear neutrons

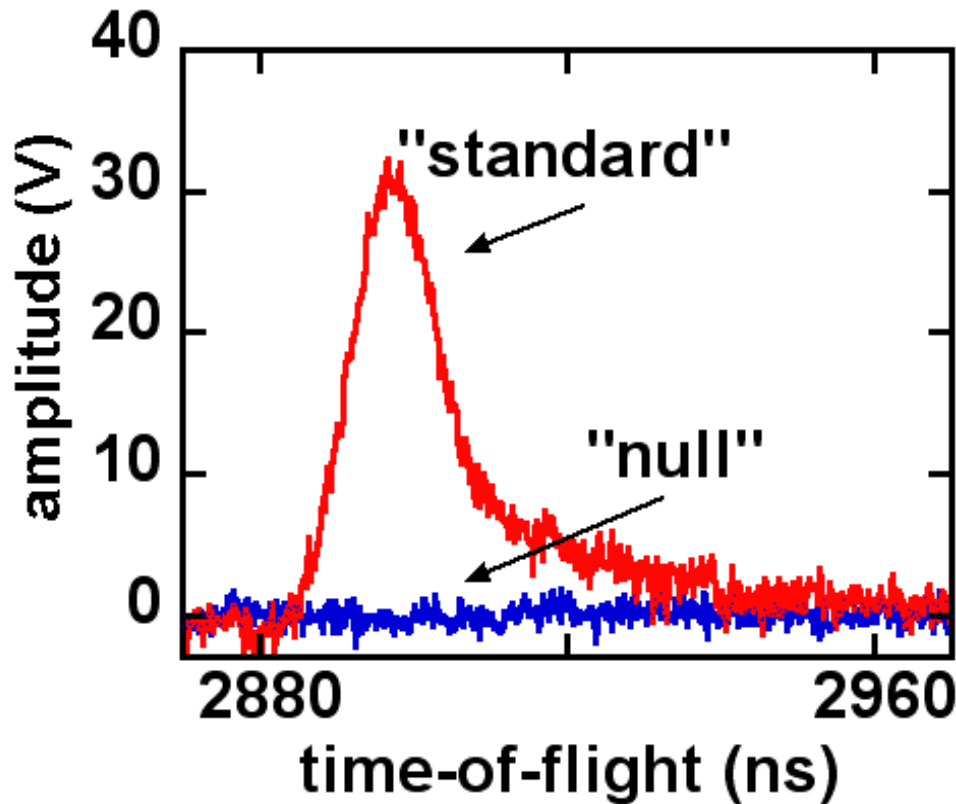

C. L. Ruiz et al., Phys. Rev. Lett. 93, 015001 (2004)  
R. J. Leeper et al., J. Phys. IV 133, 175 (2006)

Z1031 “standard” fill (24 atm D<sub>2</sub> + 0.085 atm Ar)  
Z1032 “standard” fill + 0.6 atm Xe

- On “null shots,” neutron yield measured by Be activation decreased by more than an order of magnitude



# Z answered important questions about the properties of diamond at high pressure

stress versus density for diamond

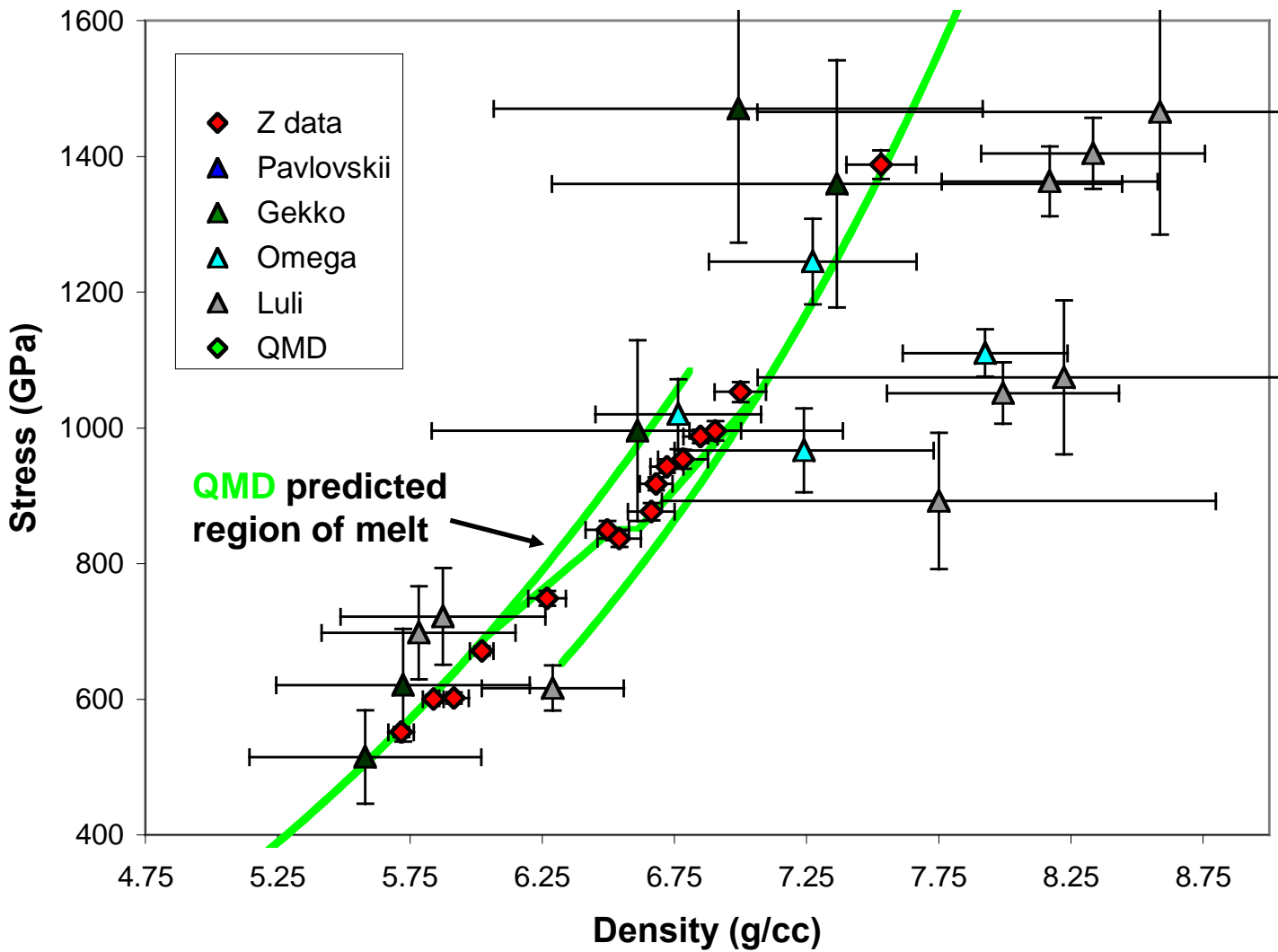

- The Z data was obtained in 1 week
- Measurements on Z have a accuracy of  $\leq 1\%$



# Magnetized Liner Inertial Fusion (MagLIF) provides beneficial effects for pulsed power driven ICF

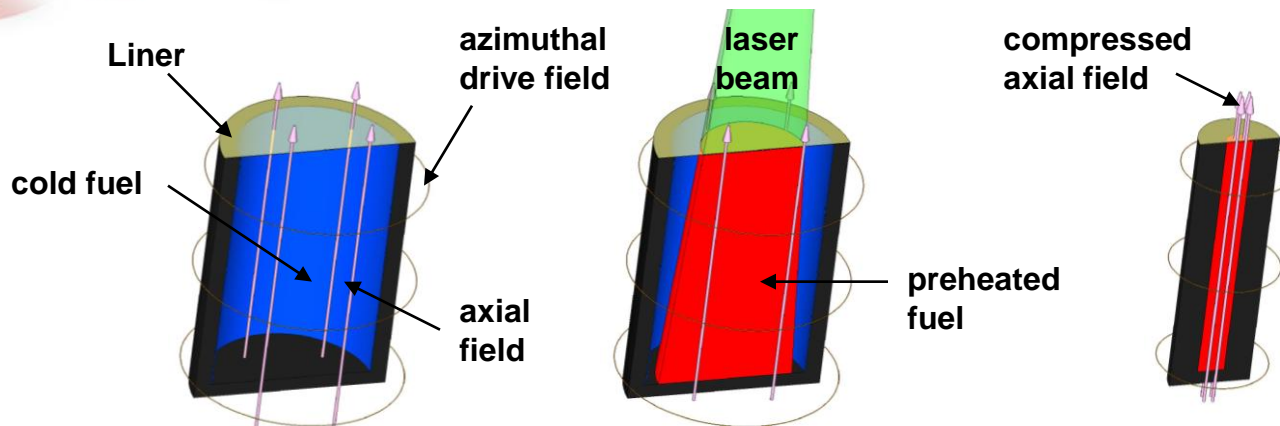

- A magnetic field inhibits thermal conduction and enhances alpha particle deposition within the fuel
- Preheating the fuel reduces the compression needed to obtain ignition temperature
  - allows relatively low velocity implosions (5-10 cm/ $\mu$ s)
  - calculations indicate this could be done by the Z Beamlet laser
- Simulations indicate significant yields on ZR with modest convergence ratios
- The Z Beamlet backlighter will enable studies of the evolution of the Magneto-Rayleigh-Taylor instability in Beryllium liners





# Refurbished Z has delivered world-record currents to Dynamic Hohlraum Z-pinch loads with $< 1\%$ shot-to-shot variation

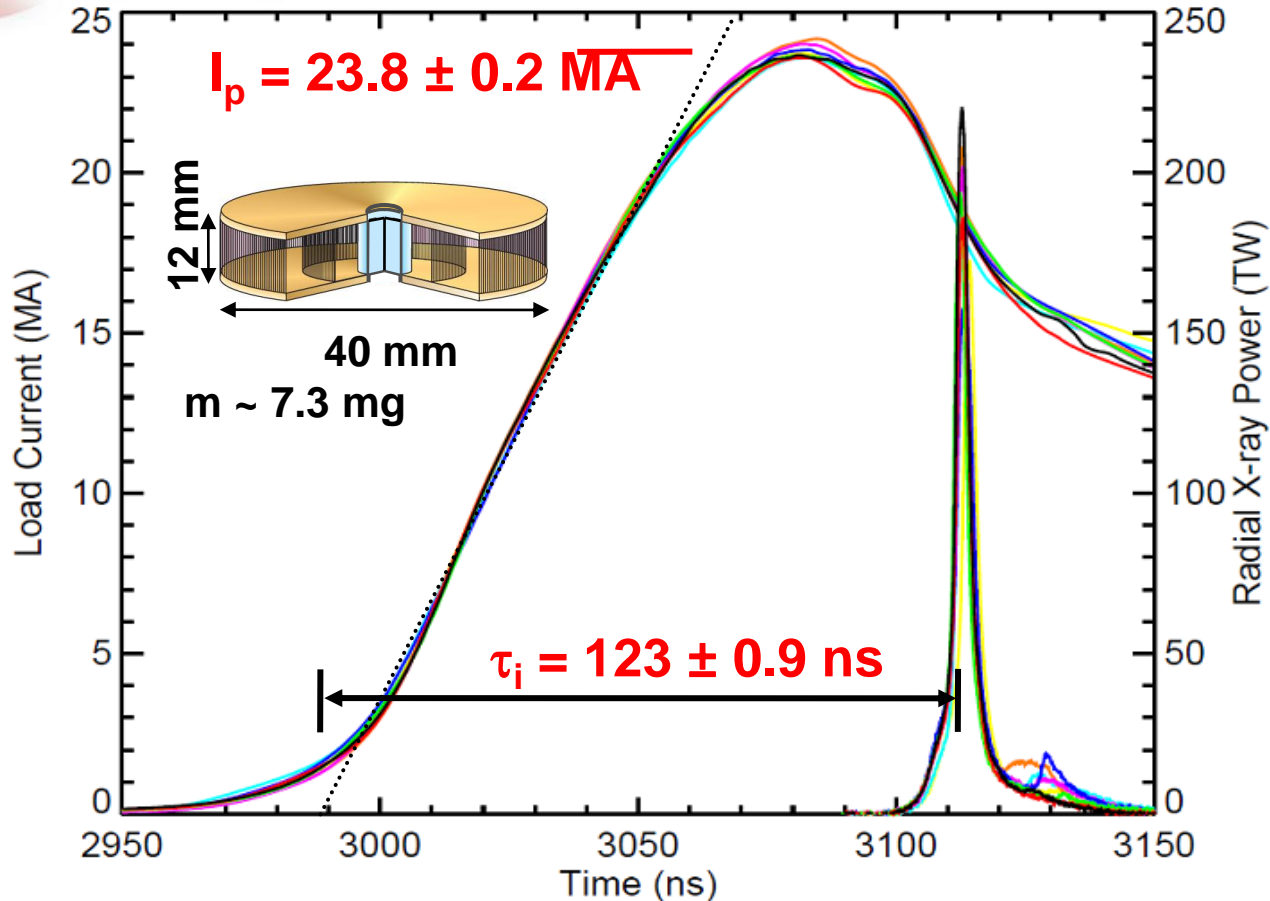

This reproducible, bright ( $\sim 200 \text{ TW}$ ) source is ideal for opacity experiments



# Opacity quantifies how transparent or opaque a plasma is to radiation

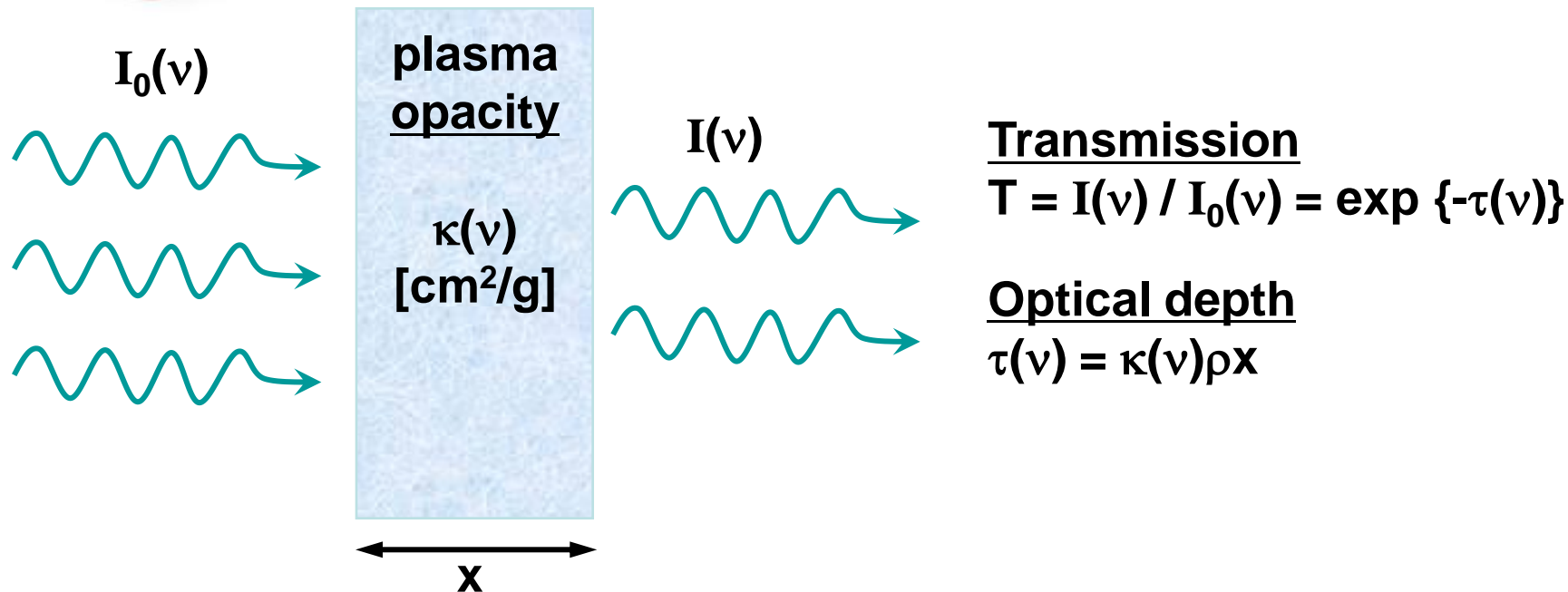

**Stellar structure depends on opacities that have never been measured**

**Challenge: create and diagnose stellar interior conditions on earth**



# Z opacity experiments reached $T \sim 156$ eV, two times higher than in prior Fe research

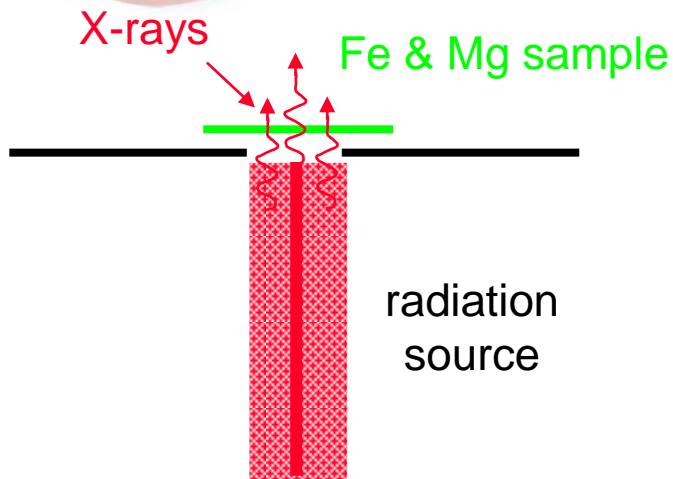

Fe + Mg at  $T_e \sim 156$  eV,  $n_e \sim 6.9 \times 10^{21}$  cm $^{-3}$

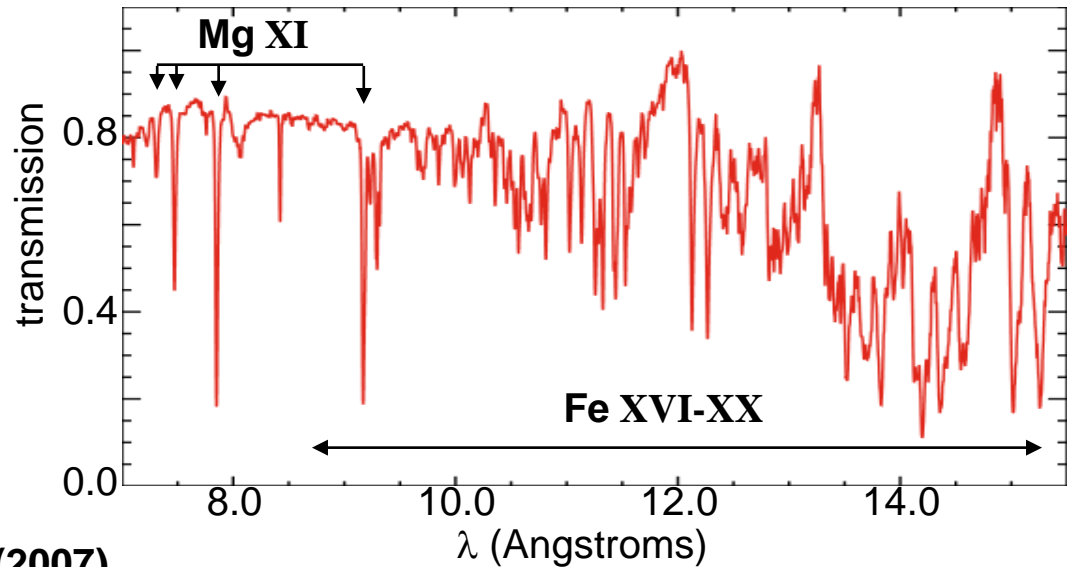

J.E. Bailey et al., PRL 99, 265002 (2007)

- Mg is the “thermometer”, Fe is the test element



PIC calculations are the first pinch calculations to predict a power law ion distribution  $E^{-\alpha}$  that has been observed in experiment

105 ns 110 ns 115 ns

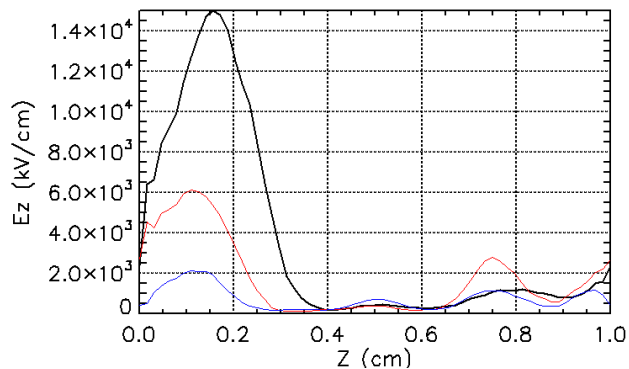

Average  $E_z$  within  
1.5 cm radius

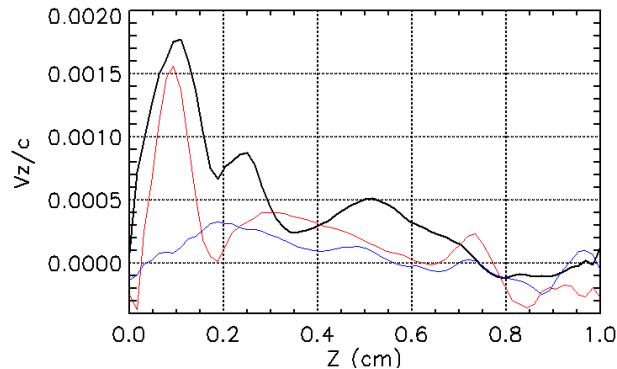

Average ion  $V_z$  within  
1.5 cm radius

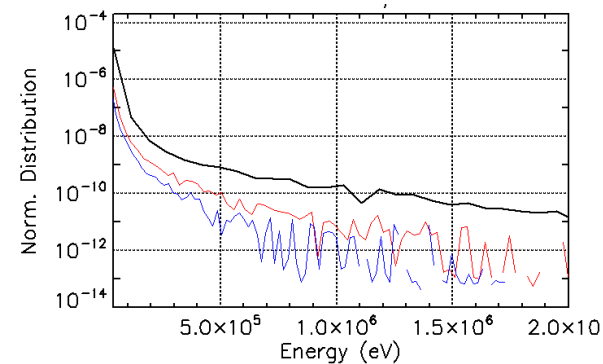

Deuterium energy  
distribution

H. L. L. Paasen et al., Phys. Fluids 13, 2606 (1970)

J. H. Lee et al., Plasma Phys. 13, 347 (1971)

W. A. Stygar et al., Nuclear Fusion 22, 1161 (1982)



# How can we use this efficient x-ray source to do ICF?

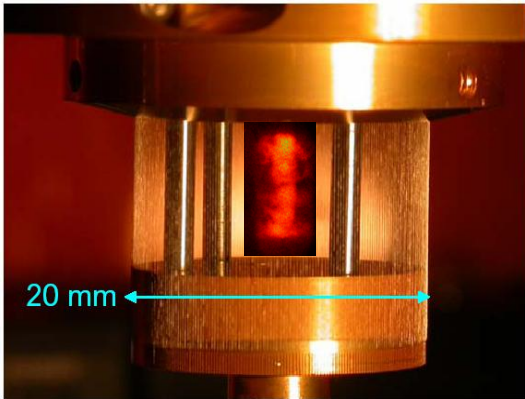

Where do we put the capsule?

We want high intensity (high Tr) for high ablation pressure  
-> let the capsule see the pinch

We need high uniformity (~1%) in x-rays the capsule sees for symmetry  
-> hide the capsule from the pinch

### Dynamic Hohlräum

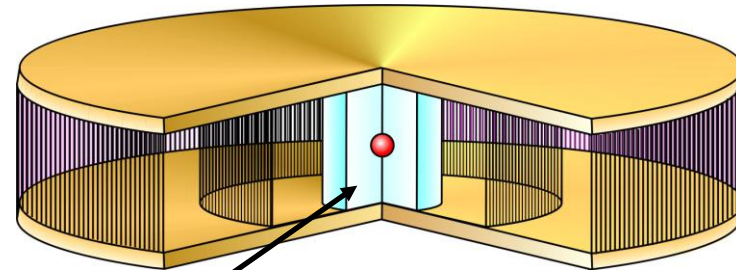

### Double-Ended Hohlräum

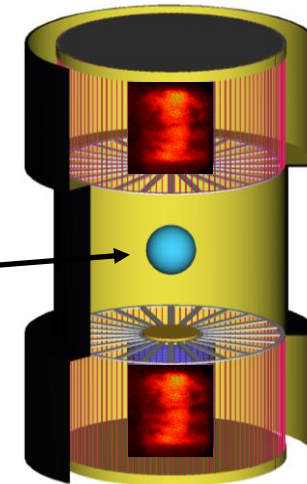

This approach is the most conservative



# Pulsed power has been investigated for over a century.

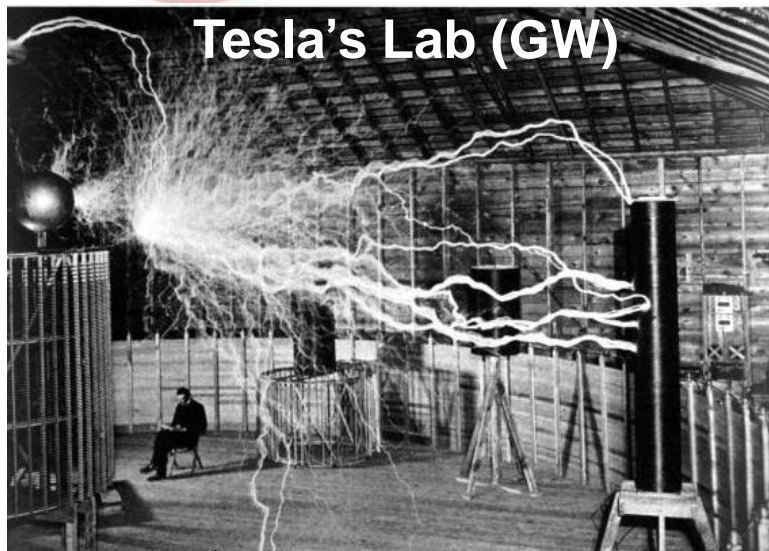

Tesla's Lab (GW)

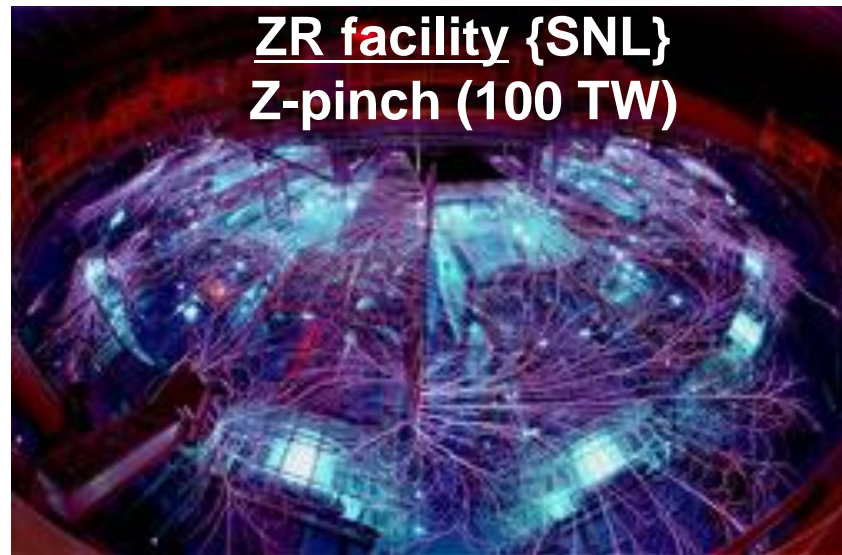

ZR facility {SNL}  
Z-pinch (100 TW)

