

CLARA Startup Procedure S-AB-P-029 Rev B

Procedure:

	Ensure that IFES Startup has been performed (S-AB-P-023) and the system is nominal	
	<ul style="list-style-type: none">• Ensure an approved pulse shape is being used.	
1	Regen startup has been performed (S-AB-P-025) <ul style="list-style-type: none">• Energy stability is within specification.• Pulse Regen Output Pointing/Centering is within specification	<input type="checkbox"/>
<hr/>		
2	Bournlea Driver startup <ul style="list-style-type: none">• Power on the Bournlea driver by depressing the 'START' button and allowing a 20 min warm-up time.• When the Start button light stops blinking, the driver is ready for operation.	<input type="checkbox"/>
<hr/>		
3	Ensure that CLARA ring is configured for laser operations <ul style="list-style-type: none">• Input Pointing/Centering is within specification.• No objects are in the beam path.• Apodizer shows no signs of damage.• Vacuum is below 5×10^{-4} Torr for the<ul style="list-style-type: none">◦ CLARA Spatial Filter and◦ SHG Spatial Filter• Pockels cell defeat waveplate is out of the beam before the PCU is activated.• Pointing and Centering must be blocked when the PCU is activated.• Verify Laser Safety Warning lights are appropriate. If not, coordinate with Shot Director to ensure appropriate warning lights.	<input type="checkbox"/>
<hr/>		
4	Verify the position of Chilled Water Supply line valves (South wall) are "OPEN". The PCU must have 4 GPM available. Note: Flow is controlled by the CLARA PCU and will not begin until the thermal sensor in the head determines that the temperature requires chilled water to remove heat.	<input type="checkbox"/>
<hr/>		
5	Check the heads for water leaks. <ul style="list-style-type: none">• If there is a leak, fix it using common sense plumbing techniques or refer to the manufacturer supplied head disassembly procedure.	<input type="checkbox"/>
<hr/>		
(continues)		
<hr/>		

-
- 6 The heat exchanger fluid level should be visible at the reservoir window.
-
- 7 Set the Main Breaker switches for rack power to the “ON” position (not shown below).
-

Below is a photograph of the CLARA Nd:YLF Head PCU Control Panel:

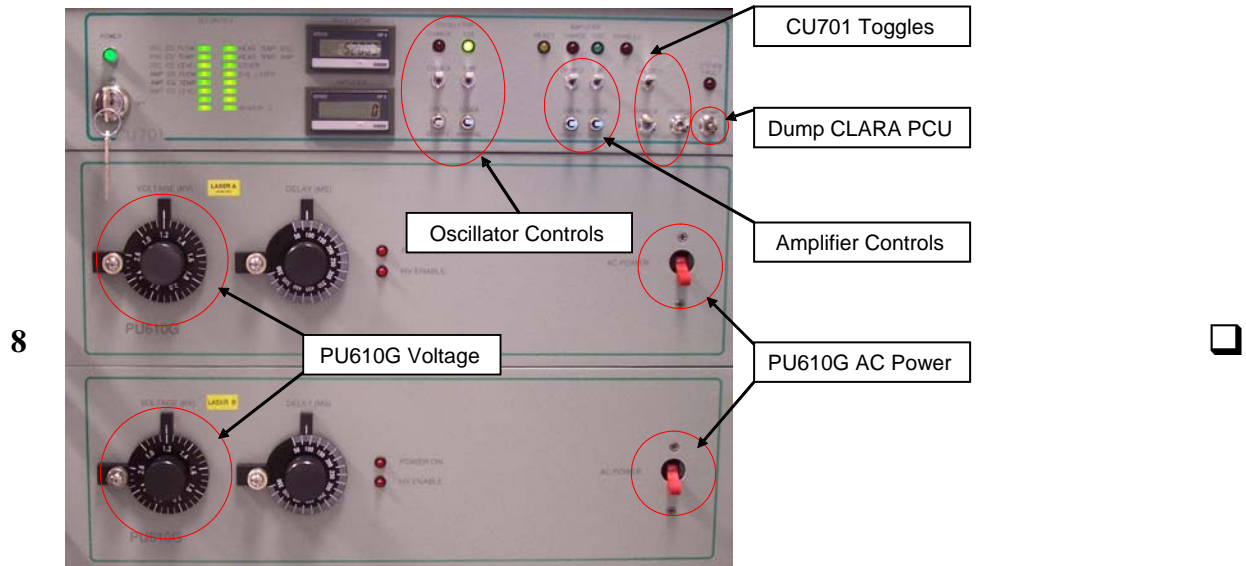

- The voltage on each PU610G unit (Laser A, B) should initially be set to 1.0 kV.
- Flip the 2-PU610G AC Power switches to their “ON” position.

-
- Turn the key of control unit CU701 to the “ON” position.
- 9
 - Frequency Toggle shall be set to Frequency A.
 - Shutter Toggle shall be set to “UP” position.
 - Coupling Toggle shall be set to “Uncoupled”.
-

Set the following amplifier toggle positions.

- 10
 - Charge shall be in “UP” position.
 - Fire shall be in the “UP” position.
 - Trigger Toggle #1 shall be in the neutral position (neither local nor remote).
 - Trigger Toggle #2 shall be in the neutral position (neither clock nor manual).
- (continues)
-

Set the following oscillator toggle positions.

- 11
- Charge shall be in “UP” position.
 - Fire shall be in “UP” position.
 - Trigger Toggle #1 shall be in the neutral position (neither local nor remote).
 - Trigger Toggle #2 shall be in the neutral position (neither clock nor manual).
-

Perform a system check by resetting the PCU using the toggle on the far right and verify that all LED indicators are lit.

- 12 Note: indicator lights are both Red and Green! If there is a fault, resolve the problem before proceeding.
-

To activate the flashlamp heads:

- Set the oscillator Trigger Toggle #1 to the REMOTE position.
- Set the oscillator Trigger Toggle #2 to the MANUAL position
- The heads will flash at 5 Hz.

Increase the voltage in increments of 0.1 kV/30 sec. from the starting value of 1.0 kV to final set point value the *Energy_Specification.xls* located in:

- 13 \\Redwood\frontend laser systems\3_laser sources\1_operations information\operational information_ energy
-

Verify spatial profile and output energy.

Allow system to warm up for 30 minutes after reaching voltage set point.

Ensure that Energy Stability at CLARA output is < 1.0% Std. Dev.

(End)